

USER MANUAL



LOW PRESSURE WATERMAKER

53421 : 15 L/H – 12 Volts
53422 : 30 L/H – 12 Volts

Warning : Please read this manual carefully before installing, using and maintaining this Plastimo watermaker. You will avoid breakdown or failure resulting from incorrect operation or misuse that would not be covered by the guarantee.

PRESENTATION

The Plastimo low pressure watermaker includes a 6 bar pump with reduced electric consumption.
The following power consumptions are given for a unit operating with 25°C and 35gr/l TDS (salinity) sea water:
- 7 Amps for the 15 L/H model
- 14 Amps for the 30 L/H model

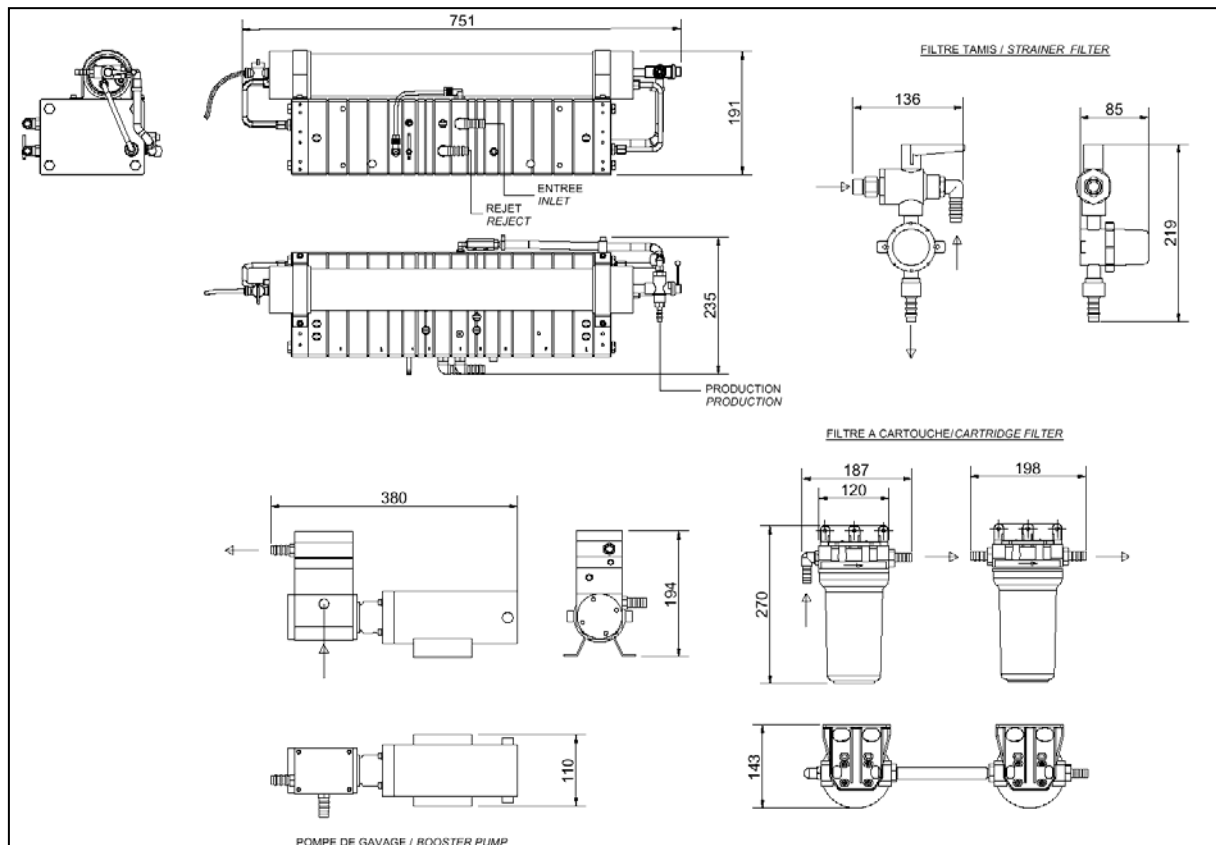

COMPONENTS

The Plastimo low pressure watermaker comes as standard with :

REP.	DESIGNATION	FUNCTION
EdM	Thru-hull inlet fitting	This sea water intake must always be immersed. It insures continuous sea water feeding of the units. Optional extra.
V0	Seacock valve	Situated close to the thru-hull inlet fitting, it is used to stop sea water feeding. Optional extra
A/B	Hoses	Feed the unit through filters (4)&(5)
1	Sea water inlet valve	The manual 3-way inlet valve feeds the unit either with sea water in normal operating conditions or with the water or the chemical solution from a watertank when rinsing, cleaning or storing the diaphragms.
2	Strainer filter	Is a fine screen filter that prevents coarse particles in, so to protect the low pressure pump (BP)
3	Low pressure pump	Driven by the electric motor; the pump rises sea water pressure to the required value between 6 and 9 bars. It must be installed under the waterline of the boat when loaded.
4	20 μ filter	Filters particles up to 20 micron
5	5 μ filter	Filters particles up to 5 micron (absolutely necessary before diaphragms)
6	Amplifier box	It rises sea water pressure to produce fresh water through reverse osmosis diaphragm.
7	Bleed valve	Bleeds the air out of the system before initial use or after having changed filters. It is also used to run the system at low pressure during rinsing, storing or maintaining operations.
8 & 21	Pressure relief valve	This valve is used to adjust pressure if it exceeds 12 and 60 bar.
10	Osmosis unit	Composed of a pressure resistant pipe including the diaphragm in which sea water is de-salinated.
11	Cleaning outlet valve	To operate in close circuit through an auxiliary watertank with maintenance fluid : turn this 3-way outlet valve on the oposite side from the reject position and turn the inlet valve (1) to rinsing position.
12	Reject/Production outlet valve	Manual 3-way valve that routes fresh water produced to the watertank (hose F) if salinity is correct or either reject it to the sea (through hose C).
C	Reject hose	Catches concentrated brine to discharge it to the sea.
R	Thru-hull outlet fitting	Fitted above the waterline, it ensures the reject of the brine to the sea. Optional extra (avoid installing this fitting before or near the inlet valve)
E	Rinsing hose	Feeds the unit with the water or the chemical fluids from the auxiliary watertank, for rinsing or cleaning diaphragms.
D	Cleaning hose	Drives the discharge water from the unit into the auxiliary watertank by switching the cleaning outlet (11), to clean the diaphragm in closed circuit..
Ech	Sampling valve	Used to sample some fresh water production for quality control.

(see Basic mounting diagram next page)

FLOW CHART

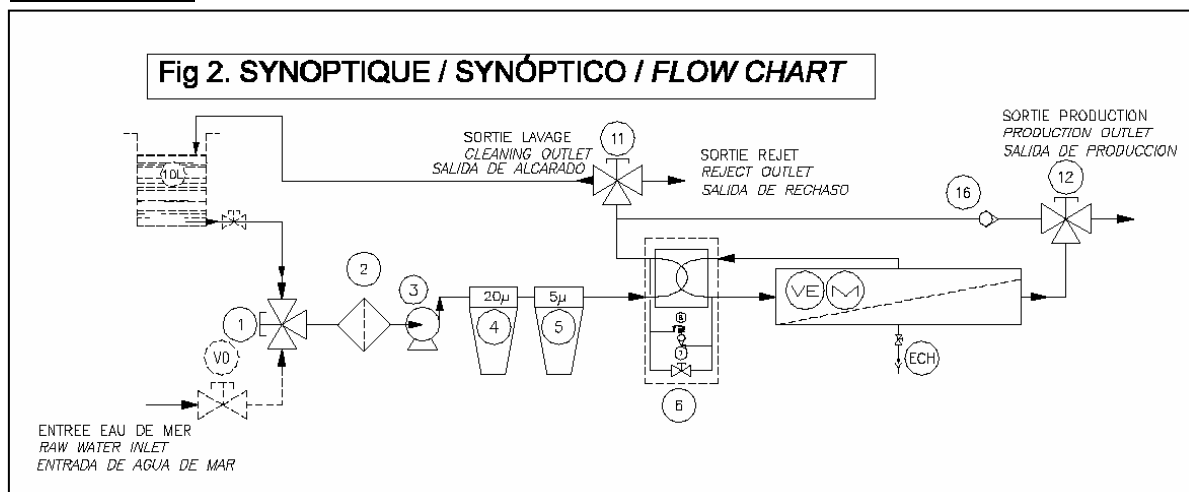

CORRECT INSTALLATIONS

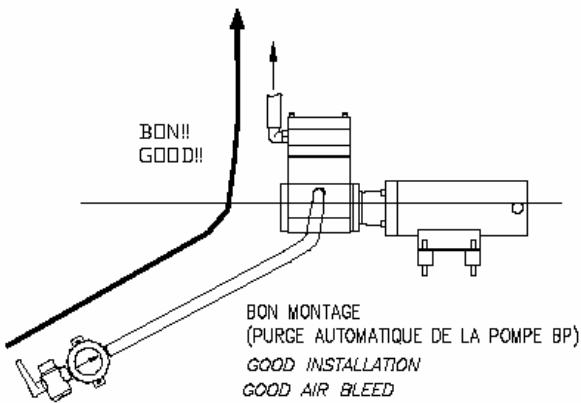
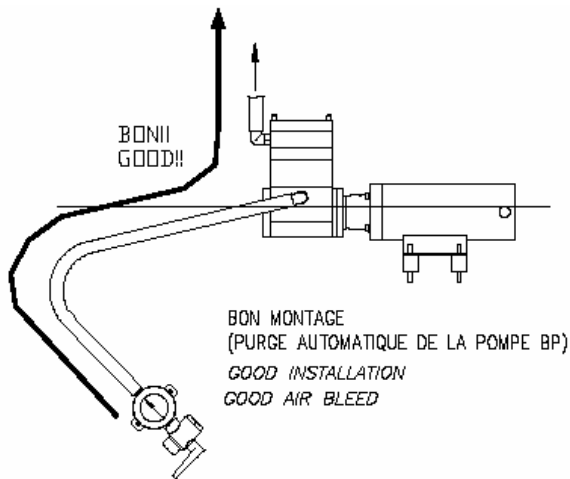

INCORRECT INSTALLATIONS

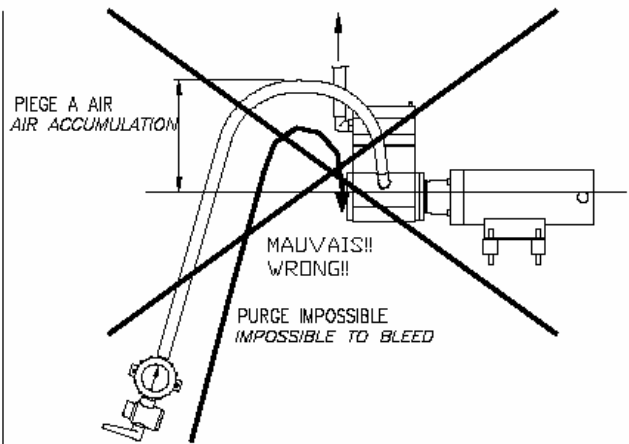
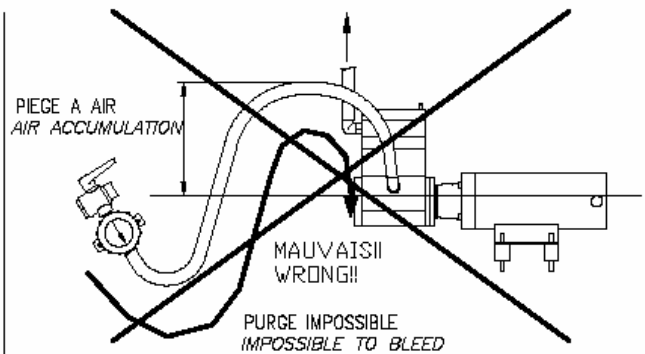

Mounting of the elements in compliance with the above diagram :

- The pump is mounted on damping pads that absorb vibrations. It must be secured on a support which is part of the boat structure. Same recommendations for the amplifier.
- If the pump is installed too far or too high from the seawater intake, cavitation can appear in the pump which will rattle. Cavitation can block the pump.
- With this model of low pressure pump you can't run the system without water. Thus it is essential that pump priming is automatic and unattended. The only way to do so is to have a rising line from the seacock valve (V0) to the 20 μ filter.
- To check if installation is correct, remove the hose which is connected to the 20 μ filter and open the valve. If installation is correct sea water should fill up the system without starting the pump. Otherwise, make necessary adjustments. The air that enters the system should escape naturally as pump discharges.



IMPORTANT

The pump must not run dry for more than 30 seconds otherwise it will break !

- Connect all the elements using the hoses enclosed :
 - o Use the 8 mm diameter hose for the fresh water circuit between the diaphragm and the watertank.
 - o Use the 15 mm diameter hose for the other connections.

WARNING :

- Most of the connections are effective under high pressure (6 or 60 bar), thus it is important to use the hoses supplied with the unit or to replace them with appropriate hoses with the same diameters, as they are designed to withstand these pressures.
- Each hose must be cut clean and perpendicularly to its axis. They must all be tighten with two clamps for additional security.

WIRING

- For power supply use a cable 2x4 mm² minimum section.

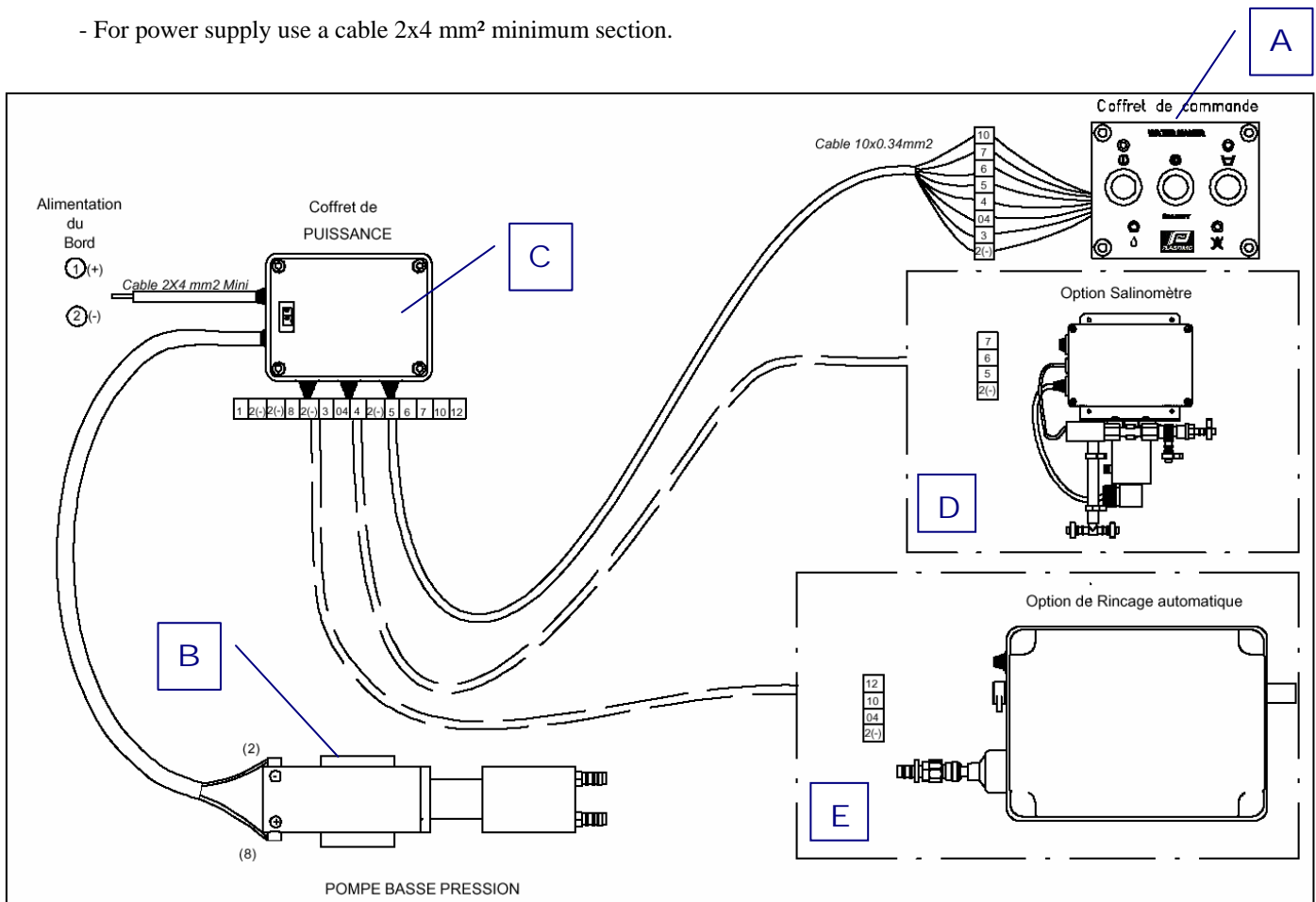

Basic electrical installation is composed of :

- A control panel (A)
- A low pressure pump (B)
- A junction box (C)

The following options can be easily connected and are pre-wired.

- An automatic salinometer (D), connect wires : (2 : blue), (5 : grey), (6 : brown), (7 : black)
- An automatic flushing (E), connect wires : (2 : blue), (04 : grey), (10 : brown), (12 : black)

Basic wiring :

1. Connect the control panel (A) to the junction box (C) with the supplied 10x0,34 mm² cable (7m length). For easier connection, follow the number code system .
2. Connect the junction box (C) to the low pressure pump (B) with the supplied 2x4 mm² cable (2m length).
3. Connect the junction box (C) to the power supply terminals with a cable minimum 2x4 mm² section if length does not exceed 10m. Otherwise use a 6 mm² cable (cable not supplied). It is not necessary to fit a switch or a fuse as they are integrated in the installation.

Optional accessories wiring :

- Each optional instrument is supplied with a 5x0,75 mm² cable. To connect the accessory to the junction box follow carefully the numbering on each cable.

FIRST STARTUP

1. Open the inlet and outlet valves.
2. Check that the strainer is not damaged (2) and that the 20 μ and 5 μ filters are not damaged.
3. Turn the sea water inlet valve (1) towards the pump.
4. Rotate the Reject/Production outlet valve (12) to the reject position.
(valve in reject position *See photo*)
5. Turn the cleaning outlet valve (11) to the reject hose.
6. You must first drain the low pressure pump by opening its bleed valve (22),
(*See photo*), the seawater must flow out freely without any air pocket.
Check that the strainer filter is filled up.
If water draining is erratic check the installation and make the necessary
recommendations (see previous page).
When the pump is filled, tighten the bleed valve (22).
WARNING : Do not touch the pump adjusting screw (21)
7. Open the bleed valve of the multiplier (7). (*See photo*)

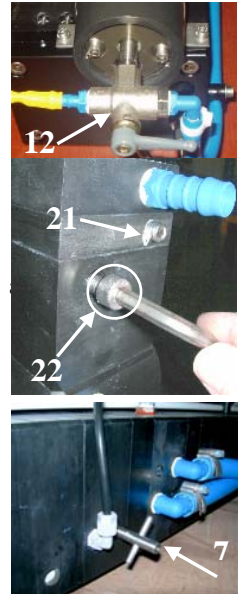

8. To start the pump press the « ON » switch on the control pannel. Make sure that the seawater flows freely through the different parts of the system and that there is a seawater flow at the reject hose level (R). Allow the pump, primary filtration and amplifier drain during at least 5 minutes and then tighten the amplifier bleed valve (7).
9. Once the amplifier bleed valve is tighten, the seawater pressure in the system will rise up to 40 to 50 bar. Then after a few minutes fresh water production will start. If the reject/production outlet valve (12) is turned to reject position, all fresh water produced is rejected to the sea. You can however see the water produced by opening the sampling valve (ECH).
10. During the first 5 minutes, the water produced is brackish. The sampling valve (ECH) enables to taste or test it with a automatic saltmeter (optional : 53428). Water is considered drinkable under 750 ppm. When salinity is correct, change reject/production outlet valve (V12) position to route fresh water to the watertank.

STARTING THE SYSTEM

1. Open the inlet and outlet valves.
2. Check that the strainer (2) and the 20 μ and 5 μ filters are not damaged.
3. Turn the sea water inlet valve (1) to the pump.
4. Turn the reject/production outlet valve (12) to reject position.
5. Turn the cleaning outlet valve (11) to the Reject position.
6. Start the pump with the "on" switch on the control pannel. If water does not flow in the system and there is not brine rejection to the sea, drain the system again as explained in the "first start up " part.
7. During the first 2 or 3 minutes, the water produced is brackish : you must throw it away. Then taste or test it with a automatic saltmeter (optional : 53428) to be sure that it is drinkable before to position the reject/production outlet valve (12) to divert water to the watertank.

STOPPING THE SYSTEM

The stopping procedure depends on how long you won't use your watermaker.

1. If the system is to be left unused for for less than 48 hours, follow the basic maintenance procedure.
2. If the system is to be left unused for a 2 days to 15 days period, perform a flushing operation cycle.
3. If the system is to be left unused for more than 15 days, you must perform a storage maintenance (sterilization).
4. At the end of the season, for winterising : flushing and storage procedure.

BASIC MAINTENANCE PROCEDURE

1. Press the « OFF » switch on the control panel.
2. Once the water production is stopped, close the seacock valve (V0) and turn the reject/production outlet valve (12) to reject position.

FLUSHING PROCEDURE

1. Press the "OFF" switch on the control panel.
2. Collect 10 litres of water from the main watertank and put them in the rinsing tank. Warning : do not use dock supply water as it contains chlorine that can damage the diaphragm.
3. Position the sea water inlet valve (1) in order that water is driven from the rinsing tank and to the low pressure pump.
4. Open the bleed valve (7).
5. Let the cleaning outlet valve (11) in reject position.
6. Start the pump by pressing the "ON" switch on the control panel. Check the water level in the tank.
7. Fresh water removes the salt from the diaphragm and avoid the development of bacteria.
8. Stop the pump before the rinsing tank is empty to avoid air entering the circuit.
9. After the pump is stopped, close the seacock valve (V0) and turn the reject/production outlet valve (12) to reject position.

STORAGE PROCEDURE

1. You need the Storage fluid (Plastimo reference 53427)
2. Follow the flushing procedure from (1) to (9) and add the storage fluid at stage (2).

WINTERISING PROCEDURE

1. You need the winterising kit (Plastimo reference 53424 : it includes a cleaning fluid, a storage fluid, 5 µ and 20 µ filters).
2. Rinse first the diaphragm with fresh water (stage 1 to 8 of the flushing procedure).
3. Fill again the rinsing tank with 10 litres of fresh water and mix the cleaning fluid.
4. Let the the sea water inlet valve (1) in pumping position, from the watertank through (E)
5. Keep the bleed valve (7) opened to avoid pressure rise in the diaphragm.
6. Turn the cleaning outlet valve (11) to the rinsing tank through the hose (D) and get a closed circuit.
7. By pressing the « ON » switch start the pump and let it run 10 minutes for a cleaning cycle.
8. After 10 minutes, flush out the cleaning solution and perform the diaphragm rinsing cycle with fresh water and then a storage maintenance procedure (see storage procedure).
9. Whatever the status of the filters (4) and (5) replace them to avoid build up of bacteria.
10. It's necessary to have water left in the diaphragm and make sure that it can't freeze.

AUTOMATIC SALTMETER (OPTIONAL)

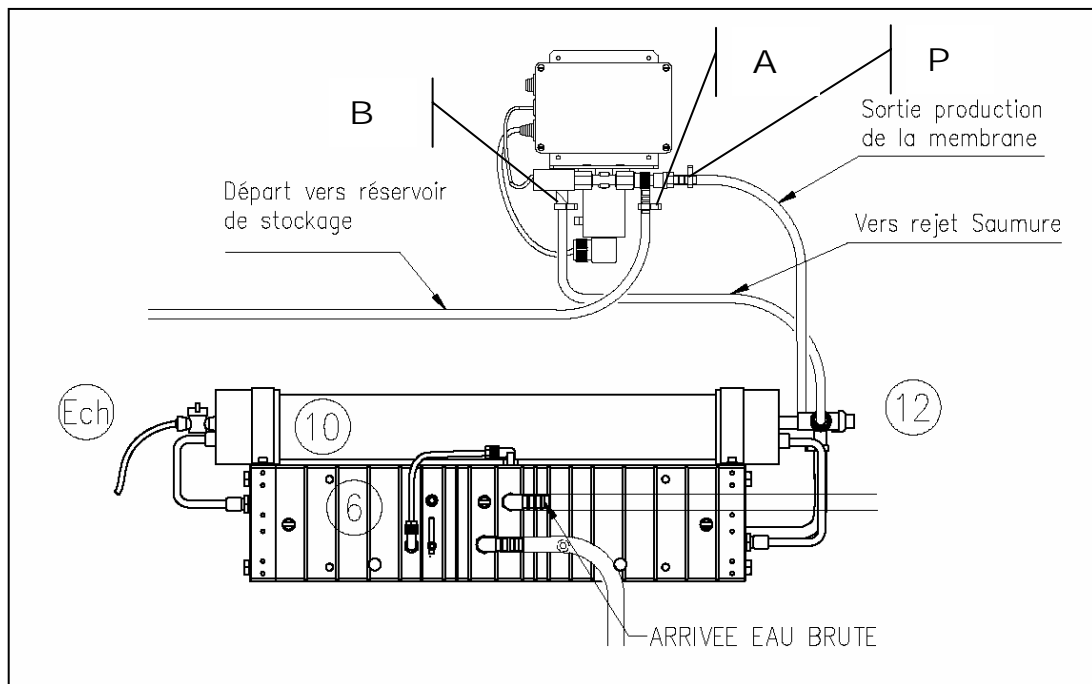

INSTALLATION

The automatic salmeter must be installed in the fresh water circuit after the diaphragm.

1. Disconnect the hose between the diaphragm outlet and the main watertank.
2. Connect the 8 mm Ø hose between the fresh water outlet of the diaphragm and the salmeter inlet. (P).
3. Connect a second hose between the salmeter outlet and the main watertank (A).
4. Connect the third hose between the reject hose of the salmeter and the reject hose of the system (B).

WIRING

The automatic salmeter is delivered with 4 wires. The 4 wires are numbered (2-), (5), (6) and (7) and must be connected to the corresponding numbers of the junction box..

OPERATION

The salmeter is completely automatic, checks constantly the salinity of the water and rejects it to the sea if the salinity level exceeds recommended level.

MAINTENANCE

Rinse the salmeter at regular intervals to avoid salt deposits (if there are deposits all water produced will be rejected into the sea).

AUTOMATIC FLUSHING (OPTIONAL)

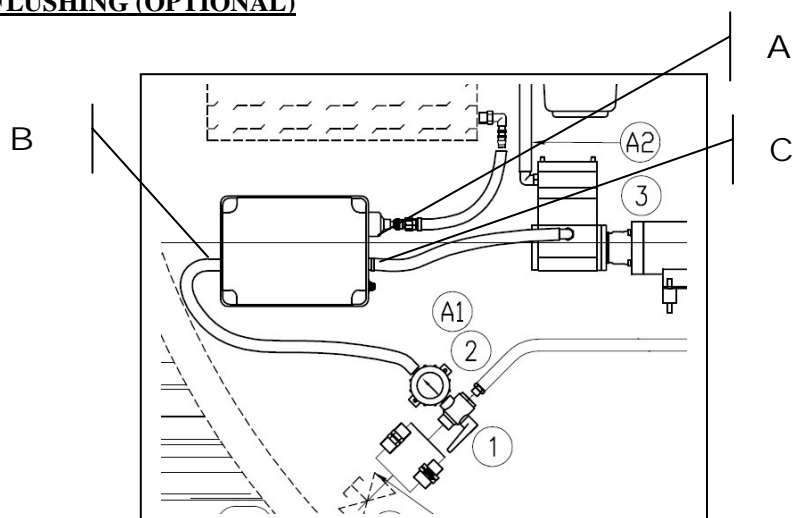

INSTALLATION

This optional device must be installed between the main freshwater watertank, the reject/production outlet valve (1) and the low pressure pump.

1. Connect the main watertank (if the watertank is situated above the rinsing instrument, you can connect it direct. Otherwise, you have to connect it to a by-pass of the under pressure fresh water distribution circuit) to the A inlet fitted with activated charcoal. This filter is used to dischlorinate the water from the watertank to protect the diaphragm (few resistant to available chlorine).
2. Connect the filter outlet (2) to the B inlet.
3. Connect the C outlet to the low pressure pump.



WARNING

Warning : when installing the automatic flushing kit do respect the installation instructions (see Main §) and avoid any air trap.

WIRING

The automatic flushing device is delivered with a 4 wires. The 4 wires are numbered (2-), (04), (10) and (12) and must be connected to the corresponding numbers of the junction box..

OPERATION

It was designed to simplify stopping procedures. For a Plastimo low pressure watermaker fitted with this optional device maintenance procedures are as follows :

STOPPING THE SYSTEM

The stopping procedure depends on how long you won't use your watermaker.

1. If the system is to be left unused for less than 48 hours, follow the basic maintenance procedure.
2. If the system is to be left unused for a 2 days to 15 days period, perform a flushing operation cycle.
3. If the system is to be left unused for more than 15 days, you must perform a storage maintenance (sterilization).
4. At the end of the season, for winterising : flushing and storage procedure.

BASIC MAINTENANCE

1. Press the « OFF » switch on the control panel.
2. Once the water production is stopped, close the seacock valve (V0) and rotate the reject/production outlet valve (12) to reject position.

FLUSHING PROCEDURE

1. Press the « OFF » button on the control panel.
2. Press the « Flushing » button. The pump is activated and pump water from the main watertank. The change of supplying source is fully automatic.
3. This optional rinsing instrument includes a timer for an automatic cut off after a few minutes.
4. When rinsing operation is over, close the seacock valve (V0) and turn the reject/production outlet valve (12) to reject position.

FLUSHING PROCEDURE

1. Position the sea water inlet valve (1) to drive water from the rinsing tank to the low pressure pump.
2. Open the bleed valve (7).
3. Put the cleaning outlet valve (11) in reject position.
4. Start the pump by pressing the "ON" switch on the control panel.
5. Fresh water removes the salt from the diaphragm and avoid the development of bacteria.
6. Stop the pump before than the rinsing tank is empty to avoid air entering the circuit.
7. After the pump is stopped, close the seacock valve (V0) and rotate the reject/production outlet valve (12) to reject position.

STORAGE MAINTENANCE

1. You need the Storage fluid (Plastimo reference 53427)
2. Press the "OFF" switch on the control panel.
3. Collect 10 litres of water from the main watertank and put them in the rinsing tank.
4. Follow the flushing procedure from (1) to (9) and add the storage fluid at stage (2).
5. Position the sea water inlet valve (1) in order to drive water from the rinsing tank to the low pressure pump.
6. Open the drain screw (7).
7. Let the cleaning outlet valve (11) in reject position.
8. Start the pump by pressing the "ON" switch on the control panel.
9. Fresh water removes the salt from the diaphragm and avoid the development of bacteria.
10. Stop the pump before than the rinsing tank is empty to avoid air entering the circuit.
11. After the pump is stopped, close the seacock valve (V0) and rotate the reject/production inlet valve (12) to reject position.

WINTERISING MAINTENANCE

You need the winterising kit (Plastimo reference 53424).

Cleaning

1. Press the "OFF" switch on the control panel.
2. Collect 10 litres of water from the main watertank and put them in the rinsing tank. Warning : do not use dock supply water as it contains chlorine that can damage the diaphragm.
3. Position the sea water inlet valve (1) in order to drive water from the rinsing tank to the low pressure pump.
4. Open the drain screw (7).
5. Turn the cleaning outlet valve (11) to the rinsing tank through the hose (D)
6. Turn the reject/production outlet valve (12) to reject position.
7. Start the pump by pressing the « ON » switch
8. Let the fluid act for at least 10 minutes
9. Stop the pump after 10 minutes, flush out the cleaning solution and start the diaphragm rinsing cycle

Storage

10. Fill again the rinsing tank with 10 litres of fresh water and add the cleaning fluid.
11. Check that the cleaning outlet valve (11) is in reject position.
12. Position the sea water inlet valve (1) in order to drive water from the rinsing tank to the low pressure pump.
13. Open the drain screw (7).
14. Start the pump by pressing the « ON » switch
15. Stop the pump before the rinsing tank is empty
16. After the pump is stopped, close the seacock valve (V0) and turn the reject/production inlet valve (2) to reject position.
17. Whatever the status of the filters (4) and (5) replace them to avoid build up of bacteria.
18. It's necessary to have water left in the diaphragm and make sure that it can't freeze.

SPARE PARTS

N°	Part number <u>SLCE</u>	Ind	Description	Model
1 & 11	711047		MANUAL VALVE 3 X F 1/2" RX	
2	710014		STRAINER FILTER PLAST MM1/2"	
3	651001		LP PUMP 150L ETW30	15L/H
	656200		DC MOTOR 12V 125W 1650T	15/30L/H
	653001		320 liters LP PUMP ETW30	30L/H
4	711002-02		O RING FILTER FATA 10"	
	711101		FILTER 7" DUPLEX ATLAS	
	711058		CARTRIDGE 7"- 20 MICRON	
	711014		CARTRIDGE 7"- 5 MICRON	
6	103121-40		S/E ETW PLAST RECUPERATOR	
7	609046		BLEED VALVE AQ-B ETW	
8 & 21	600045		Ø8 NEEDLE	
	6-66.105		SPRING ETW	
10	711205		DIAPHRAGM 4"-21 SW	
12	719251		BRASS 3-WAY VALVE 3xF 1/4	
36	724036		2.5A FUSE	
40	722072		20A UNI 3130 DC CIRCUIT BRAKER	15/30L/H
42	725090		RELAY 1RT 30A 12VCC	
50	APM- IPR3FAD2		PUSH BUTTON	
51 & 52	APM- IPR5FAD2		PUSH BUTTON	
53	OR-233358		LED INDICATOR D3 GREEN 12VCC	
54	OR-233359		LED INDICATOR D3 YELLOW 12VCC	
55	OR-233358		LED INDICATOR D3 GREEN 12VCC	
56	OR-233356		LED INDICATOR D3 RED 12VCC	
	880010		CONTROL PANNEL ETW PLAST 12 VCC	
	880030		JUNCTION BOX PLAST	

BASIC DIAGRAM

**INSTALLATION A BORD / ON BOARD INSTALLATION LAYOUT /
INSTALLACION (sans options)**

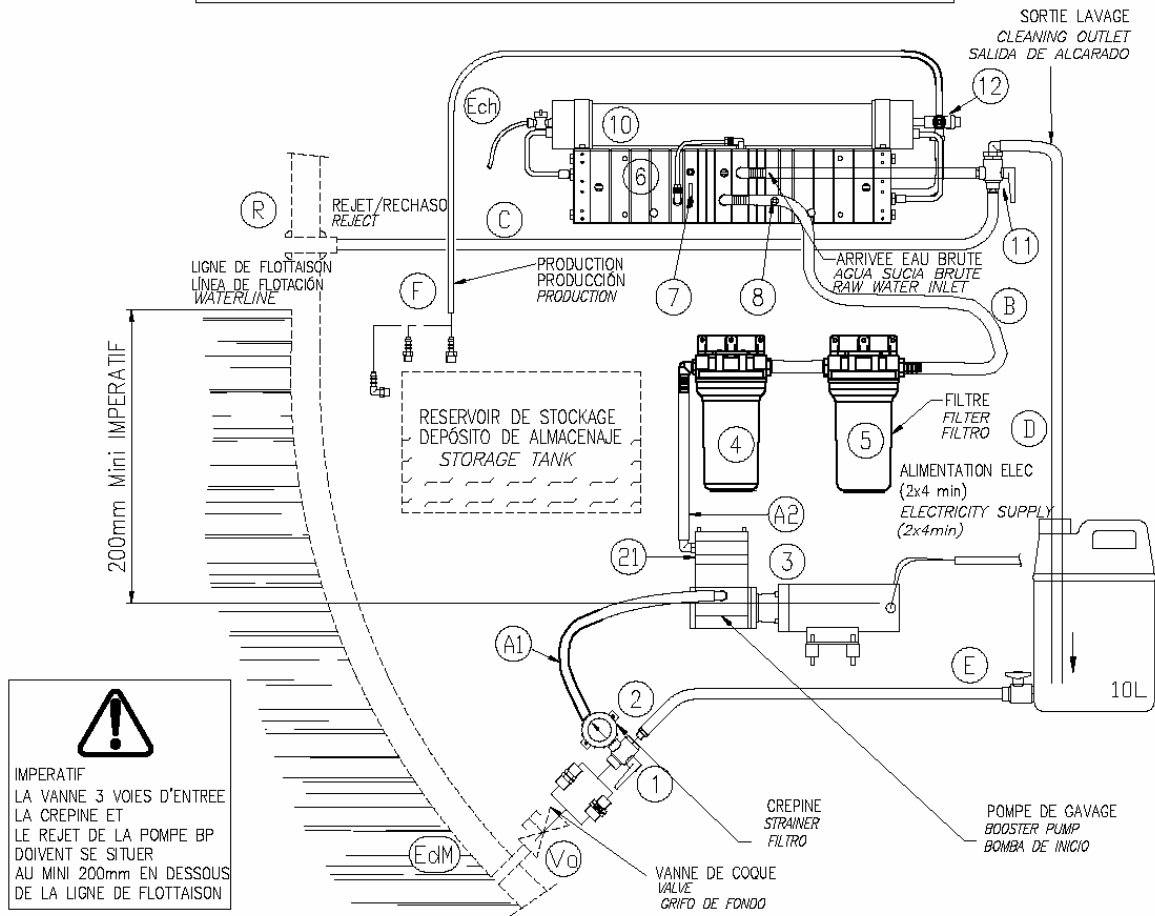

⚠ IMPERATIF
LA VANNE 3 VOIES D'ENTREE
LA CREPINE ET
LE REJET DE LA POMPE BP
DOIVENT SE SITUER
AU MINI 200mm EN DESSOUS
DE LA LIGNE DE FLOTTAISON

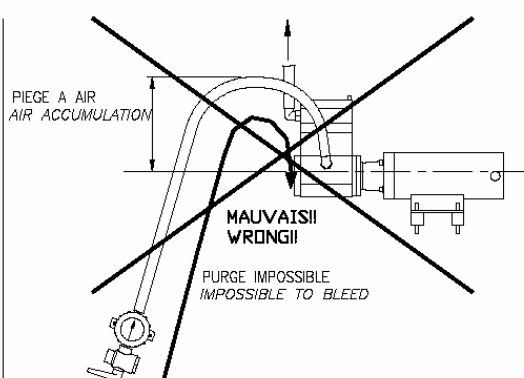
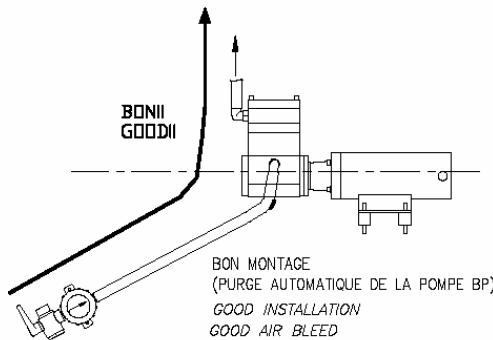
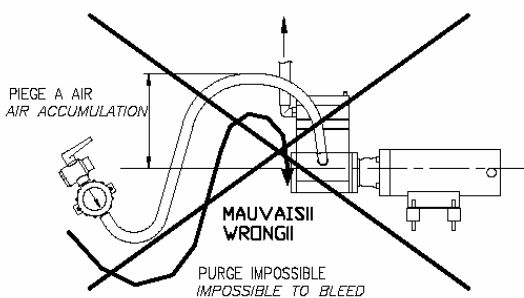
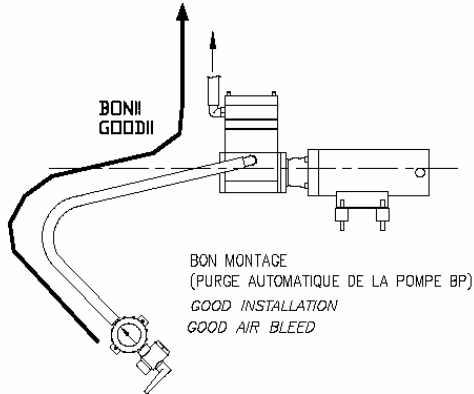

OUTLINE DIMENSION DRAWING

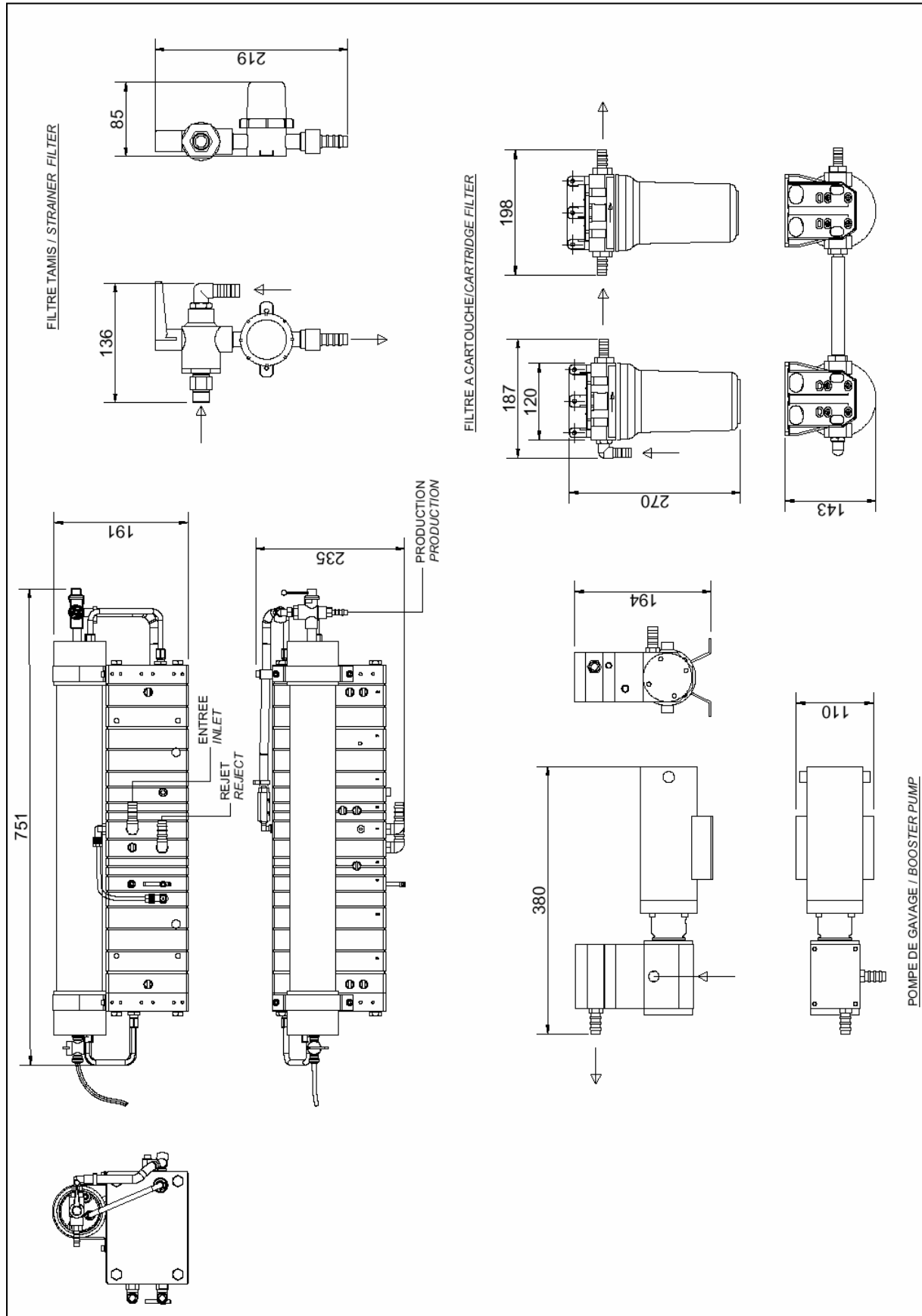

WIRING DIAGRAM

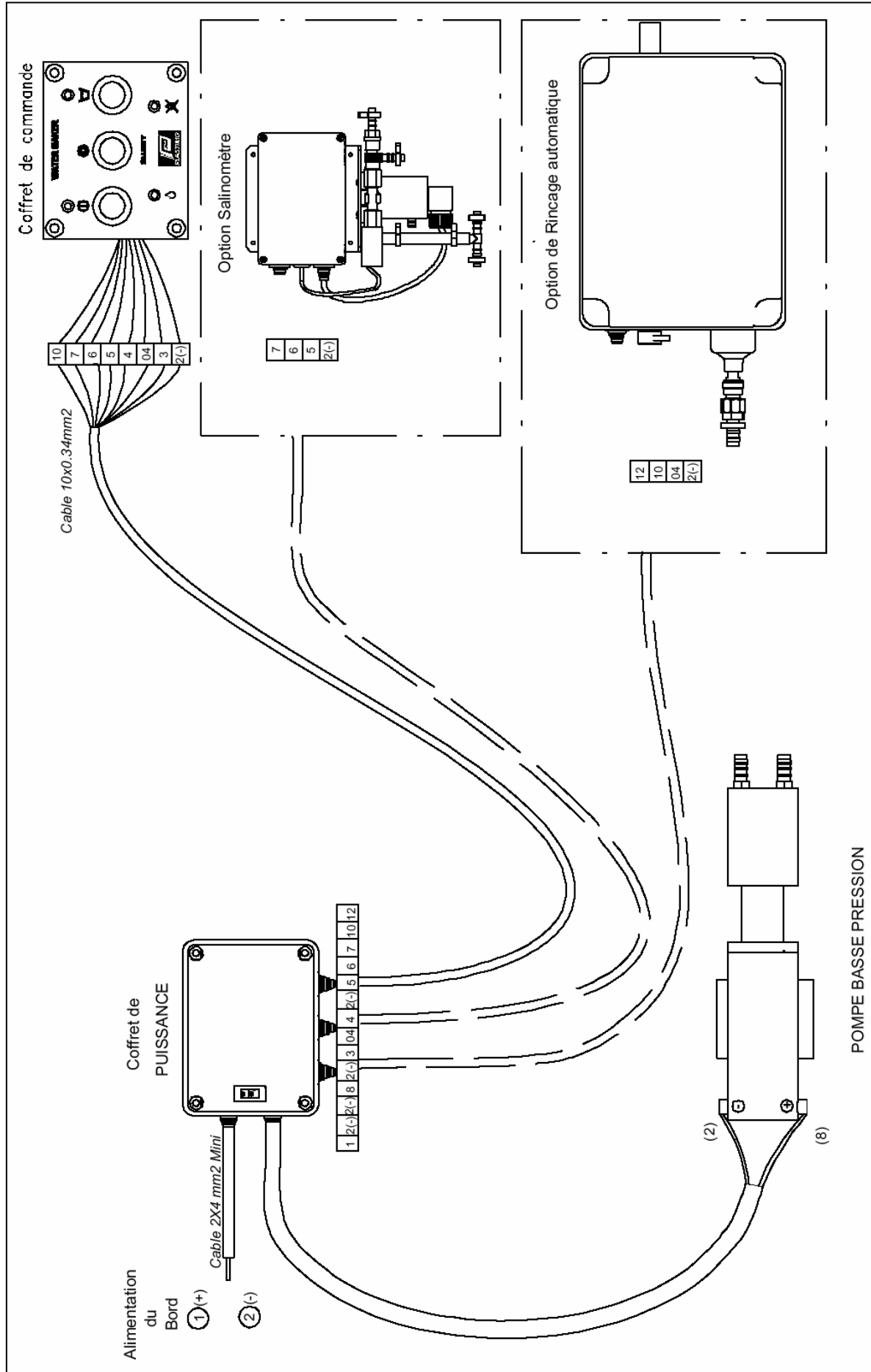

WIRING DIAGRAM

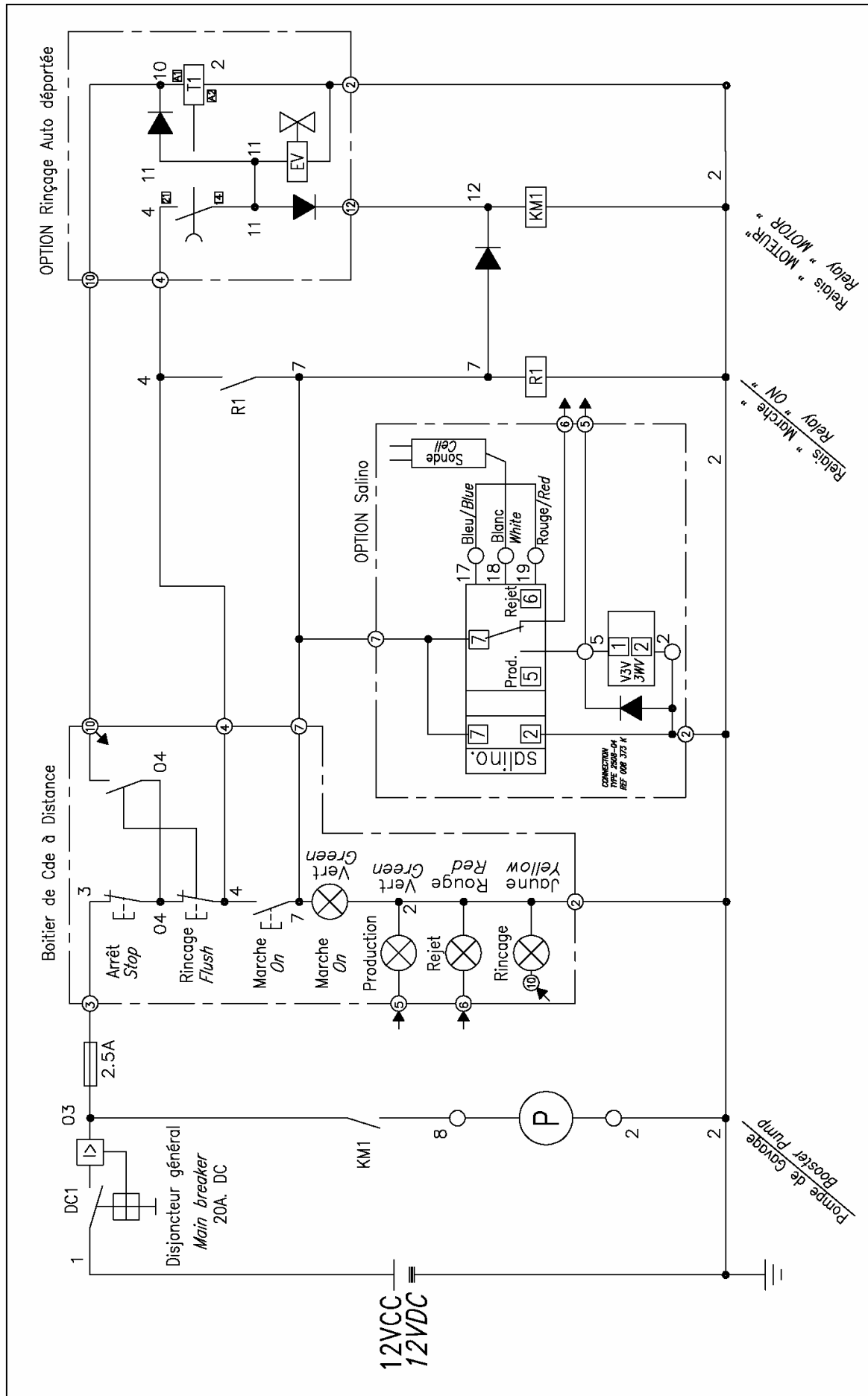

REMOTE CONTROL PANNEL

