

MULTI 3100

Installation and Operation Manual



NAVMAN



FCC Statement

Note: This equipment has been tested and found to comply with the limits for a Class B digital device, pursuant to Part 15 of the FCC Rules. These limits are designed to provide reasonable protection against harmful interference in a normal installation. This equipment generates, uses and can radiate radio frequency energy and, if not installed and used in accordance with the instructions, may cause harmful interference to radio communications. However, there is no guarantee that interference will not occur in a particular installation. If this equipment does cause harmful interference to radio or television reception, which can be determined by turning the equipment off and on, the user is encouraged to try to correct the interference by one or more of the following measures:

- Reorient or relocate the receiving antenna.
- Increase the separation between the equipment and receiver.
- Connect the equipment into an output on a circuit different from that to which the receiver is connected.
- Consult the dealer or an experienced technician for help.
- A shielded cable must be used when connecting a peripheral to the serial ports.

Contents

1 Introduction	5
2 Operation	6
2-1 Turn on and off	6
2-2 Basic operation	6
2-3 Change units	6
2-4 Alarms	6
2-5 Simulate mode	6
2-6 Key reference	7
3 Speed, average speed, maximum speed, trim speed	8
3-1 Set speed and log units	8
3-2 Reset average speed	8
3-3 Reset maximum speed	8
3-4 Reset trim speed	8
3-5 Set speed damping	8
3-6 Set speed resolution	8
3-7 Calibrate speed	8
4 Log and total log	9
4-1 Reset log	9
4-2 Reset total log	9
5 Depth, keel offset, too deep alarm, too shallow alarm	10
5-1 Set depth units	10
5-2 Set too deep alarm	10
5-3 Set too shallow alarm	10
5-4 Anchor watch	10
5-5 Set keel offset	10
6 Temperature	11
6-1 Set temperature units	11
6-2 Calibrate temperature	11
7 Countdown timer	11
7-1 Start countdown timer	11
7-2 Stop and reset countdown timer	11
7-3 Adjust start time	11
8 Systems of several instruments	12
8-1 NMEA	12
8-2 NavBus	12
9 MULTI 3100 hardware	12
9-1 What comes with your MULTI 3100	12
9-2 Other parts required	12
9-3 Transducers	13
9-4 Accessories	13

10 Installation and setup	13
10-1 Installation	13
10-2 Setup	15
10-3 Resetting to factory defaults	15
Appendix A - Specifications	15
Appendix B - Troubleshooting	16
Appendix C - How to contact us	63

Units

This unit is set up with default units of metres, °C, knots and nautical miles.

Please refer to section 2-3 of this manual to change the units.

Important

It is the owner's sole responsibility to install and use the instrument and transducer/s in a manner that will not cause accidents, personal injury or property damage. The user of this product is solely responsible for observing safe boating practices.

NAVMAN NZ LIMITED DISCLAIMS ALL LIABILITY FOR ANY USE OF THIS PRODUCT IN A WAY THAT MAY CAUSE ACCIDENTS, DAMAGE OR THAT MAY VIOLATE THE LAW.

This manual represents the MULTI 3100 as at the time of printing. Navman NZ Limited reserves the right to make changes to specifications without notice.

Governing Language: This statement, any instruction manuals, user guides and other information relating to the product (Documentation) may be translated to, or has been translated from, another language (Translation). In the event of any conflict between any Translation of the Documentation, the English language version of the Documentation will be the official version of the Documentation.

Copyright © 2002 Navman NZ Limited, New Zealand. All rights reserved. NAVMAN is a registered trademark of Navman NZ Limited.

1 Introduction

The MULTI 3100 measures and displays speed, water depth and water temperature. It can calculate and display average speed, maximum speed, trim speed, trip log (distance) and total log.

An installed MULTI 3100 usually has two parts:

- The display unit.
- Depth and speed / temperature transducers which are attached to the hull and wired to the display unit.

The unit is powered from the boat's power supply.

The MULTI 3100 is part of the NAVMAN family of instruments for boats, which includes instruments for speed, depth, wind and repeaters. These instruments can be connected together to form an integrated data system for a boat (see section 8).

For maximum benefit, please read this manual carefully before installation and use.

How the transducer measures depth

The depth transducer generates an ultrasonic (sound) pulse, which travels down through the water. When the pulse meets the bottom, some of the pulse is reflected back up towards the boat and is received by the transducer.

The display unit analyses the reflections from each pulse. It removes unwanted reflections (from bubbles and other objects) and calculates the depth by measuring the time between sending the pulse and receiving its echo.

How the transducer measures speed

The speed transducer has a small paddlewheel which spins as the boat moves through the water. The transducer measures how fast the paddlewheel is spinning and calculates the boat speed by averaging several measurements.

Cleaning and maintenance

Clean the display unit and any plastic transducers with a damp cloth or mild detergent. Avoid abrasive cleaners, petrol or other solvents.

When repainting the hull, cover or remove any visible transducers. Depth transducers may be coated with a thin layer of antifouling paint; gently sand off any previous paint first.

Do not use a high pressure water blast on the speed transducer paddlewheel as it may damage the bearings.

The MULTI 3100 display unit

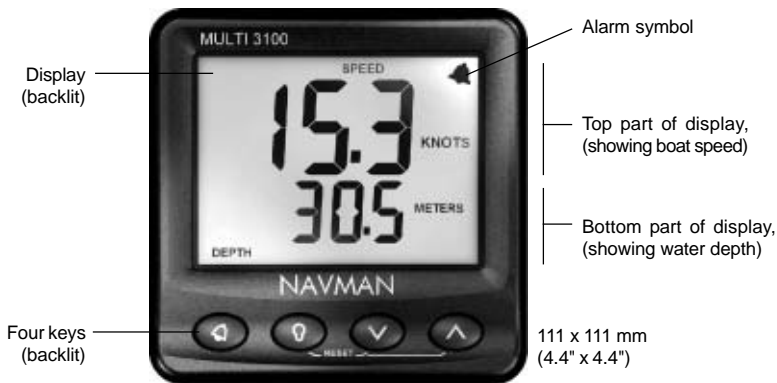

2 Operation





2-1 Turn on and off

Turn the unit on and off with the auxiliary power switch on the boat. The unit does not have its own power switch. When you turn it off, any settings you have made are retained.

If the word SIM flashes at the bottom, right of the display, then the unit is in simulate mode (see section 2-5).



2-2 Basic operation

The keys

The unit has four keys, labelled    and . In this manual:

- **Press** means to push the key for less than one second.
- **Hold** for two seconds means to hold the key down for two seconds or more.
- **Press one key + another key** means to push both keys together.

Set backlight level for screen and keys

You can set the backlight to one of four brightness levels or off. Press  once to display the current backlight level, press  again to change the level:



Backlight
Level 2

Change the items displayed

The display can show two values at once, one in the top part of the screen and one in the bottom. If an item displays as dashes (— —) then it means that the value is outside the range, for example the depth might be too deep or unknown.









To change what is displayed in the top part of the screen, press  one or more times to select:

- Speed.
- Avg speed.
- Max speed.
- Trim speed.
- Depth.
- Temperature.

To change the value displayed in the bottom part of the screen, press  one or more times to select:

- Speed.
- Depth.
- Trip log (distance).
- Total log (distance).
- Battery voltage.
- Countdown timer.

2-3 Change units

- To change the speed and log units, press  until SPEED is displayed, then hold  until the units change; if necessary, hold  again until the units change again.
- To change the depth units, press  until DEPTH is displayed, then hold  until the units change; if necessary, hold  until the units change again.
- To change the temperature units, press  until the temperature is displayed, then hold  until the units change.

2-4 Alarms

The MULTI 3100 can be set to sound an alarm when the water is too deep or too shallow (see sections 5-2 and 5-3). When the alarm sounds, the internal beeper sounds, the  symbol on the display flashes and any external beepers or lights operate.

Press  to mute the alarm. The alarm stays muted until the depth becomes returns to the pre-alarm condition or is within the alarm parameters. The alarm will sound if the depth becomes too deep or too shallow again.

2-5 Simulate mode

Simulate mode allows you to become familiar with the unit off the water. In Simulate mode, the MULTI 3100 functions normally except that the transducers are ignored and the unit generates this data internally. The word SIMULATE flashes at the bottom, right corner of the screen.

To turn Simulate mode on or off:

- 1 Turn the power off.
- 2 Hold down  while you turn the power on.

2-6 Key reference

Turn power on

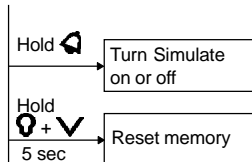

Normal operation

Hold 2 sec

+

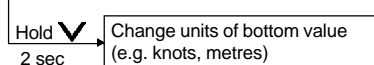
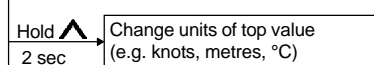
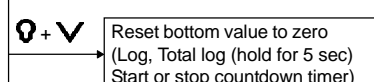
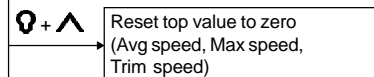
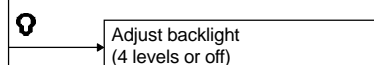
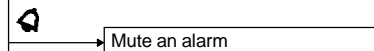
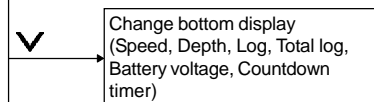
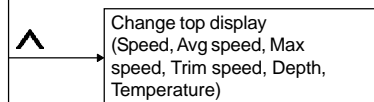

Set alarms

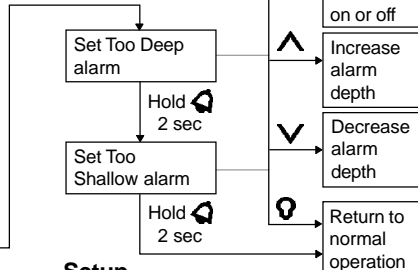

Setup

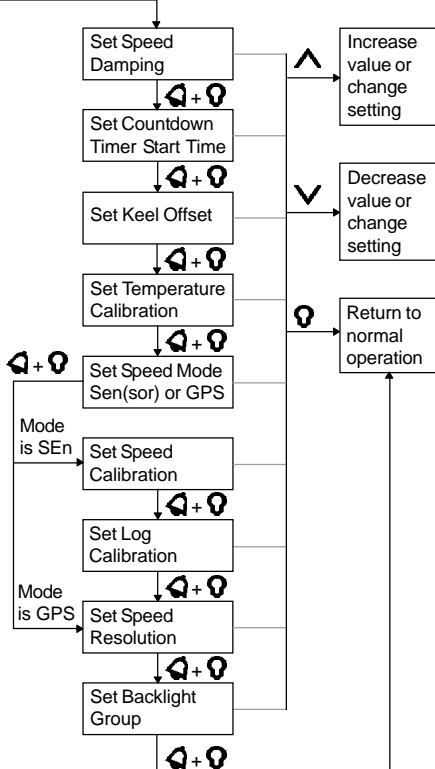

3 Speed, average speed, maximum speed, trim speed

The unit can display several speeds:

- **SPEED:** The current boat speed.
- **AVG SPEED:** The average speed since AVG SPEED was reset or the unit was switched on.
- **MAX SPEED:** The maximum speed since MAX SPEED was reset or the unit was switched on.
- **TRIM SPEED:** Trim speed may be used for tuning racing boats. Trim speed measures changes in boat speed, relative to when you reset trim speed to zero. For example, if the boat is travelling at 10 knots and you reset trim speed, then trim speed is zero. Then:
 - If the boat speed increases to 11.5 knots, the trim speed is 1.5 knots.
 - If the boat speed decreases to 8.5 knots, the trim speed is -1.5 knots.

3-1 Set speed and log units

The speed units can be selected to be KNOTS, KPH and MPH. Selecting one of these automatically sets the log distance units to NM, KM or M (miles):

- Press **▲** until SPEED is displayed, then hold **▲** until the units change; if necessary, hold **▲** again until the units change again.

3-2 Reset average speed

Resetting makes the MULTI 3100 calculate a new average speed:

- 1 Press **▲** until AVG SPEED is displayed.
- 2 Press **⊙** + **▲**.

3-3 Reset maximum speed

Resetting makes the MULTI 3100 calculate a new maximum:

- 1 Press **▲** until MAX SPEED is displayed.
- 2 Press **⊙** + **▲**.

3-4 Reset trim speed

Resetting sets the trim speed to zero:

- 1 Press **▲** until TRIM SPEED is displayed.
- 2 Press **⊙** + **▲**.

3-5 Set speed damping

Waves and wind cause the boat speed to fluctuate slightly. To give a stable reading, the MULTI 3100 calculates the boat speed and trim speed by measuring the speed several times and averaging the measurements. The speed damping value ranges from 1 to 5:

- A lower value averages readings over a shorter period of time. This gives the most accurate speed but has the most fluctuations.

- A higher value averages readings over a longer period of time. This gives the most stable speed but will ignore some true speed changes.

Set the speed damping to the lowest value which gives a stable speed reading. Values of 1, 2, 3, 4 and 5 average readings over a time period of 6, 12, 18, 24 and 30 seconds respectively. To get the most accurate, stable trim speeds, you may need to increase the damping. To set speed damping:

- 1 Press **⊙** + **⊙** several times until the Speed Damping screen is displayed:



Damping equals 3

- 2 Press **▲** or **▼** to change the damping.
- 3 Press **⊙**.

3-6 Set speed resolution

This sets how speeds are displayed. It has two settings:

- **0.0** Displays speeds as 0.0 to 19.9, 20 up.
- **0.00** Displays speeds as 0.00 to 19.99, 20.0 to 29.9, 30 up.

To set the speed resolution:

- 1 Press **⊙** + **⊙** several times until the Speed Resolution screen is displayed:



Value equals 0.0 or 0.00

- 2 Press **▲** or **▼** to change the resolution setting to 0.0 or 0.00.
- 3 Press **⊙**.

3-7 Calibrate speed

Calibration may be required, because different hull shapes have different water flow characteristics. Speed calibration can be done either by the speed or by the log, as described below. If speed readings are taken from a GPS receiver (see section 8-1), then you can not calibrate it.

Calibrate by speed

In this method, travel at a measured, constant speed. Use the speed displayed on a GPS receiver, follow another boat travelling at a known speed or make a timed run over a known distance.

Note that for accurate calibration:

- The speed from a GPS receiver should be above 5 knots.
- The speed from another paddlewheel transducer e.g. another boat - should be between 5 and 20 knots.
- Best results are achieved in calm conditions where there is minimal tidal current (best at high or low tide).

Continue travelling at this measured, constant speed and calibrate the speed as follows:

- 1 Press **Q** + **V** several times until the Speed Calibration screen is displayed (after this, it does not matter if the boat speed changes):



Measured speed

- 2 Press **^** or **v** to change the displayed speed to the measured boat speed.
- 3 Press **V**.

Calibrate by log

In this method, travel a known distance in a straight line over a course. Best results are achieved in calm conditions where there is minimal current (best at high or low tide). Tidal effects may be reduced by making the trip twice, parallel to the current, once in each direction.

- 1 At the start of the course, reset the trip log (see section 4-1). Travel in a straight line over the course, then repeat in the other direction.
- 2 At the end, note the trip log distance (see section 4).
- 3 Press **Q** + **V** several times until the Log Calibration screen is displayed:



Distance travelled

- 4 Press **^** or **v** to change the displayed distance travelled to the actual distance you travelled over the course.
- 5 Press **V**.

4 Log and total log

The MULTI 3100 has two distance logs:

- **LOG:** Trip distance. The distance travelled since log was reset.
- **TOTAL LOG:** Total distance. The distance travelled since total log was reset:



Total log

The log units are NM, KM or M (miles) and correspond to the speed units, for example if you set the speed units to KPH then the log units are KM (see section 3-1).

4-1 Reset log

Resetting zeros the log (trip distance):

- 1 Press **v** until LOG is displayed.
- 2 Press **V** + **v**.

4-2 Reset total log

Resetting zeros the total log (total distance), as well as the log and avg speed:

- 1 Press **v** until TOTAL LOG is displayed.
- 2 Hold **V** + **v** for 5 seconds.

5 Depth, keel offset, too deep alarm, too shallow alarm

Depth and keel offset

The displayed depth is the distance from the transducer on the boat to the bottom of the water, plus or minus an offset which is called the keel offset:

- A **positive** keel offset displays depth as measured from a point **above** the transducer.

For example, if you set the offset as the distance from the transducer to the surface, it

will display the depth from the surface to the bottom of the water.

- A **negative** keel offset displays depth as measured from a point **below** the transducer.

For example, if you set the negative offset as the distance from the transducer to the bottom of the keel, it will display the depth from the bottom of the keel to the bottom of the water.

Keel offset



Note: The boat illustrated uses a through hull transducer

5-1 Set depth units

The units can be METERS, FEET or FATH:

- Press **▲** until DEPTH is displayed, then hold **▲** until the units change; if necessary, hold **▲** until the units change again.

5-2 Set too deep alarm

The too deep alarm sounds if the alarm is turned on and the depth becomes equal to or more than the too deep alarm depth. To mute the alarm, press **◀**.

To set the too deep alarm:

- 1 Hold **◀** for two seconds to display the Too Deep Alarm screen:



- 2 To change the alarm depth, press **▲** or **▼**.
- 3 To turn the alarm on or off, press **◀**.
- 4 Press **⏻**.

5-3 Set too shallow alarm

The too shallow alarm sounds if the alarm is turned on and the depth becomes equal to or less than the too shallow alarm depth. To mute the alarm, press **◀**. To set the too shallow alarm:

- 1 At the Too Deep Alarm screen, hold **◀** for two seconds to display the Too Shallow Alarm screen:



- 2 To change the alarm depth, press **▲** or **▼**.
- 3 To turn the alarm on or off, press **◀**.
- 4 Press **⏻**.

5-4 Anchor watch

To set an anchor watch, set the too shallow alarm to slightly less than the current depth and set the too deep alarm to slightly more than the current depth. Allow for tide changes.

5-5 Set keel offset

Keel offset is described above. The range is ± 2.9 m (± 9.6 ft, ± 1.6 fathoms):



- 1 Press **◀** + **⏻** several times until the Keel Offset screen is displayed:
- 2 Press **▲** or **▼** to change the keel offset.
- 3 Press **⏻**.

6 Temperature

Temperature is measured by a sensor in the speed transducer.

6-1 Set temperature units

The units can be either °C or °F:

- Press **▲** until the temperature is displayed, then hold **▲** until the units change.

6-2 Calibrate temperature

The unit is factory calibrated and should not normally need calibrating. To calibrate:

- 1 Measure the water temperature near the speed transducer.
- 2 Press **◀** + **⏸** several times until the Temperature Calibration screen is displayed:



Water temperature

- 3 Press **▲** or **▼** to change the temperature to the value measured in step 1 above.
- 4 Press **⏸**.

7 Countdown timer

You can adjust the countdown timer to start counting down between one and ten minutes, in increments of one minute. The factory default start time is 10 minutes. When the timer is counting down, the countdown timer symbol flashes and the time remaining is displayed in minutes and seconds:



Countdown timer symbol flashes

Timer counting down

The beeper sounds and any external beepers or lights operate:

- Four beeps at four minutes to go.
- Three beeps at three minutes.
- Two beeps at two minutes.
- One beep at one minute.
- Ten beeps at the end; the last beep is longer and marks the end of the countdown.

In each case, the end of the last beep marks the exact minute.

7-1 Start countdown timer

The timer starts at the start time (to adjust the start time, see section 7-3).

- 1 Press **▼** until the countdown timer is displayed.
- 2 Press **⏸** + **▼**. The timer displays On briefly and starts counting down from the start time.

7-2 Stop and reset countdown timer

- 1 Press **▼** until the countdown timer is displayed.
- 2 Press **⏸** + **▼**. The timer stops and the time resets to the start time (see section 7-3).

7-3 Adjust start time

- 1 Press **◀** + **⏸** several times until the Countdown Timer Start Time screen is displayed:



Timer start time is 9 min

- 2 Press **▲** or **▼** to set the start time in minutes.
- 3 Press **⏸**. The timer does not start now (to start the timer, see section 7-1).

8 Systems of several instruments

Several NAVMAN instruments can be connected together during installation to share data. There are two ways of connecting instruments together, NavBus or NMEA.

8-1 NMEA

NMEA is an industry standard. Speed, depth, temperature and log data may be output which can be read and displayed by any compatible NAVMAN (eg REPEAT 3100) or other NMEA instrument. Speed (RMC) can be received via NMEA and displayed by the MULTI 3100 (see section 10-1 for wiring).

If an external RMC (speed) input is available from a GPS instrument, then you can set up the MULTI 3100 to use this for speed readings (see section 10-2, step 2); Note:

- A speed from a paddlewheel sensor is the speed that the boat is moving through the water. A speed from a GPS is the speed over the ground. If there is a current then these two speeds will be different.
- If a transducer is not fitted to the unit and the corresponding external data is not available then the displayed value will be 0 (for example, when using a GPS input for speed and no speed/temperature transducer is fitted then temperature displays as 0).

8-2 NavBus

NavBus is a NAVMAN proprietary system. It is high speed and allows a wide range of data to be shared by the instruments.

When instruments are connected by NavBus:

- If you change the units, alarms or calibration in one instrument, then the values will automatically change in all other instruments of the same type
- Each instrument can be assigned to a group of instruments (see section 10-2, step 3). If you change the backlight in an instrument in group 1, 2, 3 or 4 then the backlight will automatically change in the other instruments in the same group. If you change the backlight in an instrument in group 0 then no other instruments are affected.
- If an alarm sounds, mute it by pressing  on any instrument which can display that alarm. For example, mute a depth alarm on any instrument that can display depth.

If the unit does not have a depth or a speed/temperature transducer fitted then the unit will automatically take depth, speed and temperature readings from another instrument, via NavBus, if the data is available.

For more information, refer to the NavBus Installation and Operation manual.

9 MULTI 3100 hardware

9-1 What comes with your MULTI 3100

The MULTI 3100 comes in several configurations.

Standalone configuration

- MULTI 3100 unit with protective cover.
- Warranty card.
- Mounting template.
- This *Installation and Operation Manual*.

In addition, the standalone configuration usually requires a depth transducer and a speed/temperature transducer (see section 9-3).

Kit configuration

The MULTI 3100 is available in several kit configurations with different grades of through hull transducer, with:

- The parts for the standalone configuration, listed above.
- Through hull depth transducer.
- Through hull speed/temperature transducer.
- *Transducer Installation Manual*.

9-2 Other parts required

One or more 3100 series instruments will be connected to the boat 12 V power supply via:

- An accessory switch to turn the instruments on and off.
- A fuse. Use a 1 A fuse for between one and five instruments.

Optional external beepers or lights can be fitted. The MULTI 3100 output is switched to ground, 30 V DC and 250 mA maximum. If the beepers and lights require more than 250 mA, fit a relay.

For systems of several instruments, wiring and connectors are required (see section 8 or your *NavBus Installation and Operation Manual*).

9-3 Transducers

The MULTI 3100 is usually used with a through hull depth transducer and a separate through hull speed/temperature transducer. However, the unit can take readings from another instrument, in which case it may not need transducers (see section 8).

Through hull transducers generally give the best performance and are the best choice for displacement hulls. They are mounted in a hole drilled through the bottom of the boat.

- Plastic through hull transducers are suitable for GRP or metal hulls.
- Bronze transducers are suitable for wood or fibreglass hulls. Never install a bronze transducer in a metal hull, because it will cause electrolytic corrosion.

A range of NAVMAN through hull transducers are available, plus in hull and transom mount transducers. For more information, refer to the

Transducer Installation manual or consult your NAVMAN dealer.



9-4 Accessories

These accessories are available from your NAVMAN dealer.



4 m speed transducer extension cable



4 m depth transducer extension cable



Through hull speed transducer skin fitting



Through hull speed paddlewheel



NavBus junction Box (See section 8)

10 Installation and setup

Correct installation is critical to the performance of the unit. It is vital to read this section of the manual and the documentation that comes with the other parts before starting installation.

The MULTI 3100 can:

- Drive external beepers or lights for the alarm and countdown timer.
- Send and receive data from other NAVMAN instruments connected via NavBus. Settings for alarms, units, calibration and backlighting are shared (see section 8).
- Send and receive NMEA data from other instruments.

Warnings

The unit is waterproof from the front. Protect the rear of the unit from water, or else water might enter the breathing hole and damage the unit. The warranty does not cover damage caused by moisture or water entering the back of the unit.

The choice, location, angle and installation of the transducers is the most critical part of the installation. If they are not correct, the unit can not perform at its designed potential. If in doubt, consult your NAVMAN dealer. Plastic through hull transducers are usually unsuitable for wood hulls. If in doubt, consult a marine surveyor or marine engineer.

Ensure that any holes that you cut will not weaken the boat's structure. If in doubt, consult a qualified boat builder.

10-1 Installation

MULTI 3100 display unit

- 1 Choose a location for the display unit that is:
 - Easily seen and protected from damage.
 - At least 100 mm (4") from a compass and at least 500 mm (19.5") from a radio or radar antenna.

- Away from engines, fluorescent lights, power inverters and radio or radar transmitters.
 - Accessable from behind; the minimum clearance required at the back is 50 mm (2") (see mounting diagram).
 - With the back of the unit protected from moisture.
- The unit must mount on a flat panel which is less than 20 mm (0.75") thick. Stick the mounting template in place. Drill a 50 mm (2") fixing hole through the centre hole in the template. Note that the template allows space around the unit for the protective cover.
 - Remove the fixing nut from the back of the unit. Insert the stud at the back of the unit through the mounting hole. Hand tighten the fixing nut.

Transducers

- If the MULTI 3100 does not come with transducers, choose suitable transducers (see section 9-3). If the MULTI 3100 is supplied with transducers, see section 9-3 to ensure that they are suitable.
- Choose suitable locations for the transducers and install them by following the instructions in the Transducer Installation manual.
- Fit the cables between the transducers and the display unit:
 - Keep the cable away from other cables, engines, fluorescent lights, power inverters and radio or radar transmitters.
 - Do not lay the cable in the bilge.
 - If necessary, extend the cable by adding extension cables.
 - Do not cut the cable on any depth transducer.
 - Secure the cable at regular intervals.
- Connect the transducers to the display unit connectors.

Side view of display unit mounting

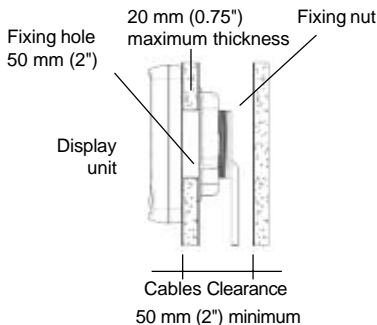

Power/data wiring

- Wire the display unit power/data cable:
 - The unit requires 12 V DC power. Fit a power switch and fuse to the power supply or power the unit from a fused auxiliary switch. The fuse should be 1 A for up to five instruments.
 - If the external beepers and lights require more than 250 mA DC total, fit a relay.

A single unit can be wired as shown below:

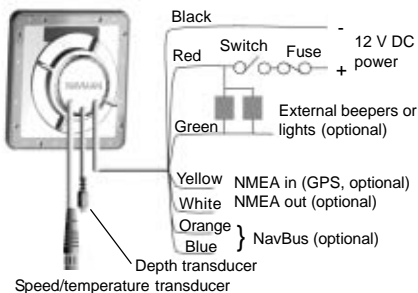

With several instruments, use the optional junction boxes to simplify wiring, as shown below:

For information on how to connect NavBus and to use junction boxes, refer to the NavBus Installation and Operation manual.

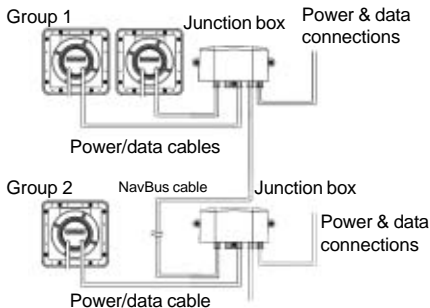

- Tape or cover any unused wires or connectors to protect them from water and keep them from shorting together.

10-2 Set up

- Take the boat for a trial run to check that all the instruments work correctly.
- If the unit will take speed readings from a GPS receiver, rather than a speed transducer or an NAVMAN MULTI 3100 Installation and Operation Manual

external speed input from an instrument with a speed transducer (see section 8-1):

- i Press **Q** + **V** several times until the Speed Mode screen is displayed:
- ii Press **^** or **v** to change the mode to GPS (when using a speed transducer, the mode should be SEN).
- iii Press **Q**.



- 3 If the unit is part of a system of 3100 series instruments connected by NavBus, set the unit's backlight group number (see section 8):

- i Press **Q** + **V** several times until the Backlight Group screen is displayed:
- ii Press **^** or **v** to set the backlight group number.
- iii Press **Q**.

- 4 Set:



- Speed and log units (see section 3-1).
- The speed resolution (see section 3-6).
- The depth units (see section 5-1).
- The keel offset (see section 5-5).
- The temperature units (see section 6-1).

- 5 Calibrate if required:

- Speed (see section 3-7).
- Temperature (see section 6-2).

10-3 Resetting to factory defaults

All settings may be reset to the manufacturer's default settings (see below).

To reset to factory defaults:

- 1 Turn the power off.
- 2 Hold down **Q** + **v** while you turn the power on and continue to hold the keys down for at least five seconds.

Speed units	Knots
Depth units	Metres
Temperature units	°C
Speed resolution	0.0
Speed damping	2
Keel offset	0
Depth alarms	Off
Countdown timer start time	10 min
Distance logs	0
SIMULATE mode	Off
Backlight Level	0
Backlight Group	1

Appendix A - Specifications

Physical

- Case size 111 mm (4.4") square.
- LCD display 82 mm (3.2") wide, 61 mm (2.4") high; twisted nematic.
- LCD digits 30 mm (1.2") high on top line, 20 mm (0.8") high on bottom line.
- Four operator keys, laser etched
- Backlighting for display and keys, amber, four levels and off.
- Operating temperature 0 to 50°C (32 to 122°F)
- Transducer cable length 8 or 9 metres (26.25 or 29.5 ft).
- Power Cable length 1 m (3.25 ft).

Electrical

- Power supply 10 to 5 to 16.5 V DC, 30 mA without backlighting, 200 mA with full backlighting and transducer.
- External beeper or light output, switched to ground, 30 V DC and 250 mA maximum.

Speed

- Displays current speed, average speed, maximum speed, trim speed.
- Range 0 to 50 knots (0 to 58 mph, 0 to 93 km/h).
- Display resolution either 0.0 to 19.9, 20 up or 0.00 to 19.99, 20.0 to 29.9, 30 up.
- Trim speed displays $\pm .00$ to $.99$, 1.0 to 9.9, 10 up
- Adjustable damping for speed and trim speed gives stable readings in all sea conditions; values of 1, 2, 3, 4 & 5 average readings over a time period of 6, 12, 18, 24 & 30 seconds respectively.

Log

- Displays trip log and total log.
- Range 0 to 99999 km, miles or nautical miles.
- Displays 0.00 to 999.99, 1000.0 to 9999.9, 10000 up.

Depth

- Range 0.5 to 130 m (1.5 to 400 ft, 0.3 to 67 fa).
- Typical accuracy < 2% (depends on type of depth transducer, installation and water clarity).
- Displays 0.0 to 19.9, 20 up.
- Adjustable keel offset ± 2.9 m (± 9.6 ft, ± 1.6 fa)
- Too Deep and Too Shallow alarms (run both at once to provide anchor watch facility).

Temperature

- Range 0 to 37.7°C (32 to 99.9°F); typical accuracy < 2°C.
- Resolution 0.1 degree.

Countdown timer

- Can be set to between 1 and 10 minutes, in increments of 1 minute.
- Counts down in minutes and seconds.

Calibration

- Speed and temperature can be calibrated.

Interfaces

- NavBus connection to other NAVMAN instruments.
- NMEA 0183 outputs: DBT, DPT, PTTKD, PTTKV, VHW, MTW, VLW; input RMC.

Standards compliance

- **EMC compliance**
 - **USA (FCC):** Part 15 Class B.
 - **Europe (CE):** EN50081-1, EN50082-1
 - **New Zealand and Australia (C Tick):** AS-NZS 3548.
- Environment: IP66 from front when correctly mounted.

Power/data cable wires

Wire	Signal
Red	Power positive, 12 V DC, 200 mA maximum
Black	Power negative, NMEA common
Green	External beeper or light out, switched to ground, 30 V DC and 250 mA max.
Orange	NavBus +
Blue	NavBus -
White	NMEA out
Yellow	NMEA in

Appendix B - Troubleshooting

This troubleshooting guide assumes that you have read and understood this manual.

It is possible in many cases to solve difficulties without having to send the unit back to the manufacturer for repair. Please follow this troubleshooting section before contacting the nearest NAVMAN dealer.

There are no user serviceable parts. Specialized methods and testing equipment are required to ensure that the unit is reassembled correctly and is waterproof. Repairs to the unit must only be carried out by a service centre approved by NAVMAN NZ Limited. Users who service the unit themselves will void the warranty.

More information can be found on our website: www.navman.com

1 Unit will not turn on:

- a Fuse blown or circuit breaker tripped.
- b Battery voltage is outside the range 10.5 to 16.5 V DC.
- c Power/data cable damaged.

2 Speed reading wrong or erratic:

- a Calibration is incorrect (see section 3-7).
- b Speed transducer cable unplugged or damaged.
- c Speed/temperature transducer fouled or damaged. Check paddle wheel is aligned fore and aft in the fitting. Remove paddlewheel from fitting, check for fouling or damage. Spin paddlewheel by hand, check for a speed reading.
- d Speed transducer installed incorrectly or transducer does not have a smooth flow of clear water over it. Review installation.
- e Interference from electrical noise. Review installation.

3 Depth reading wrong or erratic:

- a Unit temporarily unable to detect bottom, for example water too deep or too shallow, water not clear, boat reversing and transducer in turbulent water.
- b Depth transducer cable unplugged or damaged.
- c Depth transducer fouled or damaged. Check for fouling, damage or too thick a layer of paint over it.
- d Depth transducer installed incorrectly or transducer does not have a smooth flow of clear water over it. Review installation.
- e Interference from the ultrasound pulse from another depth sounder.
- f Interference from electrical noise. Review installation.

To check the transducer, disconnect it and connect a known good transducer temporarily. Hold it over the side of the boat in the water and check if the unit displays a depth.

4 Temperature reading wrong:

- a Calibration is incorrect (see section 6-2).
- b Speed/temperature transducer cable damaged.

5 The word SIM flashes at bottom, right of screen, values displayed are unexpected:

- a Unit is in simulate mode (see section 2-5).

6 The display fogs:

- a Moist air has entered the breathing tube at the rear of the unit. Air the boat or run unit with backlight fully on.
- b Water has entered the breathing tube. Return unit for service.

NORTH AMERICA**NAVMAN USA INC.**

18 Pine St. Ext.
Nashua, NH 03060.
Ph: +1 603 577 9600
Fax: +1 603 577 4577
e-mail: sales@navmanusa.com

OCEANIA**New Zealand**

Absolute Marine Ltd.
Unit B, 138 Harris Road,
East Tamaki, Auckland.
Ph: +64 9 273 9273
Fax: +64 9 273 9099
e-mail:
navman@absolutemarine.co.nz

Australia**NAVMAN AUSTRALIA PTY**

Limited
Unit 6 / 5-13 Parsons St,
Rozelle, NSW 2039, Australia.
Ph: +61 2 9818 8382
Fax: +61 2 9818 8386
e-mail: sales@navman.com.au

SOUTH AMERICA**Argentina**

HERBY Marina S.A.
Costanera UNO,
Av Pte Castillo Calle 13
1425 Buenos Aires, Argentina.
Ph: +54 11 4312 4545
Fax: +54 11 4312 5258
e-mail:
herbymarina@ciudad.com.ar

Brazil**REALMARE**

Estrada do Joa 3862,
CEP2611-020,
Barra da Tijuca, Rio de Janeiro,
Brasil.
Ph: +55 21 2483 9700
Fax: +55 21 2495 6823
e-mail:
vendas@marinedepot.com.br

Equinautic Com Imp Exp de Equip Nauticos Ltda.

Av. Diario de Noticias 1997 CEP
90810-080, Bairro Cristal, Porto
Alegre - RS, Brasil.
Ph: +55 51 3242 9972
Fax: +55 51 3241 1134
e-mail:
equinautic@equinautic.com.br

ASIA**China**

Peaceful Marine Electronics Co. Ltd.
Hong Kong, Guangzhou,
Shanghai, Qindao, Dalian.
E210, Huang Hua Gang Ke Mao
Street, 81 Xian Lie Zhong Road,
510070 Guangzhou, China.
Ph: +86 20 3869 8784
Fax: +86 20 3869 8780
e-mail:
sales@peaceful-marine.com
Website:
www.peaceful-marine.com

Korea

Kumho Marine Technology Co. Ltd.
604-816, 3F, 1117-34,
Koejung4-Dong, Saha-ku
Pusan, Korea
Ph: +82 51 293 8589
Fax: +82 51 294 0341
e-mail: info@kumhomarine.com
Website:
www.kumhomarine.com

Malaysia

Advanced Equipment Co.
43A, Jalan Jejaka 2, Taman
Maluri, Cheras 55100, Kuala Lumpur.
Ph: +60 3 9285 8062
Fax: +60 3 9285 0162
e-mail: ocs@pc.jaring.my

Singapore

RIQ PTE Ltd.
Blk 3007, Ubi Road 1,
#02-440, Singapore 408701
Ph: +65 6741 3723
Fax: +65 6741 3746
HP: +65 9679 5903
e-mail: riq@postone.com

Thailand

Thong Electronics (Thailand)
Company Ltd.
923/588 Thaprong Road,
Mahachai,
Muang, Samutsakhon 74000,
Thailand.
Ph: +66 34 411 919
Fax: +66 34 422 919
e-mail: thonge@cscoms.com

Vietnam

Haidang Co. Ltd.
16A/A1E, Ba thang hai St.
District 10, Hochiminh City.
Ph: +84 8 86321 59
Fax: +84 8 86321 59
e-mail:
sales@haidangvn.com
Website: www.haidangvn.com

MIDDLE EAST

Lebanon and Syria
Letro, Balco Stores,
Moutran Street, Tripoli
VIA Beirut.
Ph: +961 6 624512
Fax: +961 6 628211
e-mail: balco@cyberia.net.lb

United Arab Emirates
Kuwait, Oman & Saudi Arabia
AMIT, opp Creak Rd.
Baniyas Road, Dubai.
Ph: +971 4 229 1195
Fax: +971 4 229 1198
e-mail: mksq99@email.com

AFRICA

South Africa
Pterec (Pty) Ltd Coastal,
Division No.16 Paarden Eiland Rd.
Paarden Eiland, 7405
Postal Address: PO Box 527,
Paarden Eiland 7420
Cape Town, South Africa.
Ph: +27 21 511 5055
Fax: +27 21 511 5022
e-mail: info@kfa.co.za

EUROPE

France, Belgium and
Switzerland
PLASTIMO INTERNATIONAL
15, rue Ingénieur Verrière,
BP435,
56325 Lorient Cedex.
Ph: +33 2 97 87 36 36
Fax: +33 2 97 87 36 49
e-mail: plastimo@plastimo.fr
Website: www.plastimo.fr

Germany

PLASTIMO DEUTSCHLAND
15, rue Ingénieur Verrière
BP435
56325 Lorient Cedex.
Ph: +49 6105 92 10 09
+49 6105 92 10 10
+49 6105 92 10 12
Fax: +49 6105 92 10 11
e-mail:
plastimo.international@plastimo.fr
Website: www.plastimo.de

Italy

PLASTIMO ITALIA
Nuova Rade spa, Via del Pontasso 5
I-16015 CASELLA SCRIVIA (GE).
Ph: +39 1096 8011
Fax: +39 1096 8015
e-mail: info@nuovarade.com
Website: www.plastimo.it

Holland
PLASTIMO HOLLAND BV.
Industrieweg 4,
2871 VE SCHOONHOVEN.
Ph: +31 182 320 522
Fax: +31 182 320 519
e-mail: info@plastimo.nl
Website: www.plastimo.nl

United Kingdom
PLASTIMO Mfg. UK Ltd.
School Lane - Chandlers Ford
Industrial Estate,
EASTLEIGH - HANTS SO53 ADG.
Ph: +44 23 8026 3311
Fax: +44 23 8026 6328
e-mail: sales@plastimo.co.uk
Website: www.plastimo.co.uk

Sweden, Denmark or Finland
PLASTIMO NORDIC AB.
Box 28 - Lundenvägen 2,
47321 HENAN.
Ph: +46 304 360 60
Fax: +46 304 307 43
e-mail: info@plastimo.se
Website: www.plastimo.se

Spain

PLASTIMO ESPAÑA, S.A.
Avenida Narcís Monturiol, 17
08339 VILASSAR DE DALI,
(Barcelona).
Ph: +34 93 750 75 04
Fax: +34 93 750 75 34
e-mail: plastimo@plastimo.es
Website: www.plastimo.es

Other countries in Europe
PLASTIMO INTERNATIONAL
15, rue Ingénieur Verrière
BP435
56325 Lorient Cedex, France.
Ph: +33 2 97 87 36 59
Fax: +33 2 97 87 36 29
e-mail:
plastimo.international@plastimo.fr
Website: www.plastimo.com

REST OF WORLD /
MANUFACTURERS
NAVMAN NZ Limited
13-17 Kawana St. Northcote.
P.O. Box 68 155 Newton,
Auckland, New Zealand.
Ph: +64 9 481 0500
Fax: +64 9 480 3176
e-mail:
marine.sales@navman.com
Website:
www.navman.com

Made in New Zealand
MN000132 1951318B

MULTI 3100

Lon 174° 44.535' E

Lat 36° 48.404' S

NAVMAN

FC  CE