



NAVMAN



Contents

Specification	6
Installation	7
Location	7
Mounting	7
Wiring Connection	8
Multiple Instruments	8
Operation	9
Changing Functions	9
The Depth Alarms	10
Setting Alarms	10
Set Shallow Alarm	10
Set Deep Alarm	10
Select Temperature Units	10
Select Depth Units	10
Timer Functions	11
Elapsed Timer	11
Count Down Timer	11
Select Speed/Log Units	12
Reset Log (Trip Distance)	12
Reset Total Log (Total Distance)	12
Reset Average Speed	12
Reset Max Speed	12
Backlighting On / Off	12
Simulation Mode	12
Secondary Functions	13
Calibration Procedures	14
Keel Offset	14
Transducer Setting	14
Calibrate Temperature Display	14
Speed Calibration	15
Speed Comparison Method	15
Log Calibration Method	15
Troubleshooting Chart	16

Specification

- Power Supply**
 10.7 to 16.6 VDC, 90 mA nominal, 100 mA with backlights on full.
- Operating temperature**
 0°C to 45°C.
- Size of display**
 112 x 112 x 24mm (4.4 x 4.4 x 1"), overall depth 35mm (1.4") behind panel.
- Display type.**
 Twisted Nematic (TN) grey background.
- Illumination**
 Red LED switchable from key pad.
- RF interference**
 Negligible interference on any VHF marine radio channel with 3dB gain antenna at 1 metre from the instrument display head.
- Depth**
 1 to 130 metres or 3 to 400ft or 0.5 to 70 fathoms.
- Alarms**
 Depth shallow and deep. Audio and LCD flag.
- Depth unit selection**
 Feet, metres or fathoms, key pad selectable.
- Transducer**
 200 kHz, 600 ohm, 1500pF parallel capacitance.
- Boat speed**
 0 to 50 knots or 0 to 90kph or 0 to 60Mph, may be different for transducers other than that supplied with instrument. User selectable to display in 0.1 or 0.01 increments.
- Speed units and resolution**
 0.00 to 19.90 and then 20 to 50 in knots, Mph or kph.
- Maximum speed**
 Records max. speed to 50 knots. Reset to zero via key pad or at power down.
- Log (Trip distance)**
 0 to 99999 units key pad selectable in Kts, Mph or kph. Shows two decimal places when value is below 1000. Shows one decimal place if value is between 1000 and 10000.
- Total log**
 0 to 99999 units key pad selectable in Kts, Mph or kph. Shows two decimal places when value is below 1000.
- Keel Offset**
 ±9.9 ft, ±1.6 fathoms or ±3.0 metres, user settable. Allows for display of depth below keel or waterline.
- Trend Indication**
 Arrows indicate increasing or decreasing depth and speed trends.
- Time functions**
 Trip timer to 99 hrs and 59 minutes. Count down timers in seconds, start selectable from 1 to 10 minutes.
- Water temperature**
 0.0°C to 37.7°C (32.0°F to 99.9°F). Tenths of a degree are displayed.
- Temperature Sensor**
 Thermistor, 10k ohm at 25°C.
- Output data**
 NMEA 0183 format. VHW, VLW, MTW, DBT, DPT.
- Transducer input cables**
 Phono connector for depth, 4 pin Fuji for speed/temp transducer. 3 conductor cable for NMEA and power.

Display is backlit for Night Operation

Multi-function display

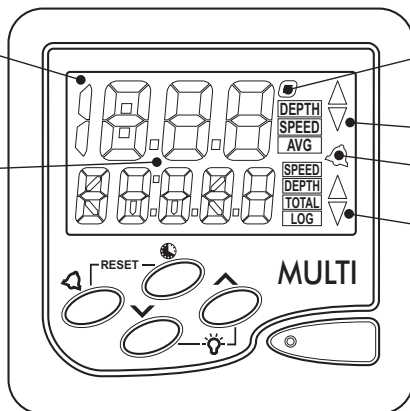

Sea temperature

Depth/speed trend indicators

Alarm indicator

Depth/speed trend indicators

Installation

Location

The NAVMAN M100 is designed for above or below deck installation. Select a position that is:

- At least 300mm from a compass
- At least 500mm from any radio
- Easy to read by the helmsman and crew
- Protected from physical damage
- Accessible to electrical cable connections
- Protected from water spray reaching rear of instrument.

Mounting

The mounting surface must be flat. Use the template to set the centre of the fixing hole.

- Drill a 32mm (1.25") diameter mounting hole through the bulkhead.
- Remove the fixing nut. Peel the protective paper off the foam gasket and attach the gasket to the rear of the instrument.
- Insert the instrument through the bulkhead. Hand tighten the nut and then finally tighten with a spanner. Do not over tighten so that the water sealing ability of the gasket is damaged.

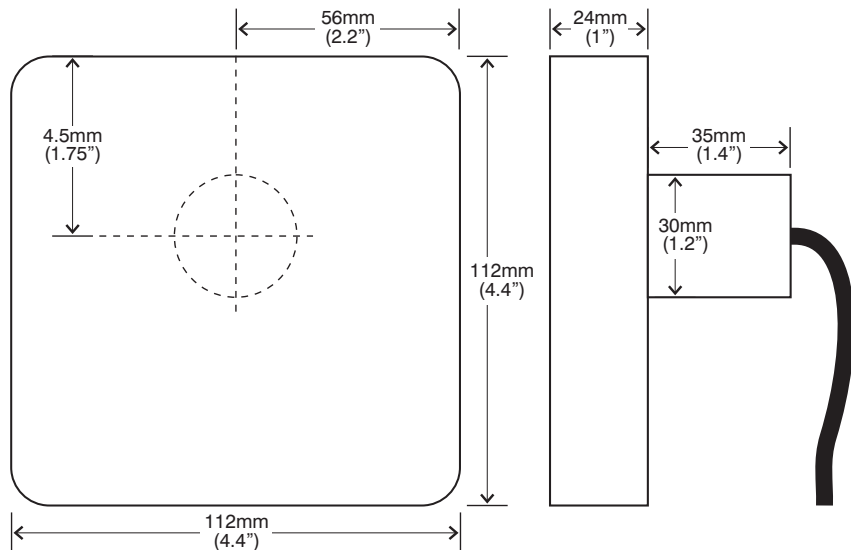

Wiring Connection

- Keep electrical and transducer cables away from alternator or other noise generating electrical cables. Avoid connecting the instrument to power circuits that share loads with ignition, alternators, inverters and radio transmitters. Electrical power supply connections should always be as short as possible.
- Connect the red wire to the positive supply via a 1 amp fuse or a 1 amp circuit breaker. Connect the black wire to the electrical ground (negative terminal of battery). A 1 amp fuse will provide protection for up to five 100 series instruments.
- Connect the 4 pin Fuji connector to the Speed and Temperature transducer.
- Connect the RCA phono connector to the depth transducer cable connector. Do not cut or shorten the depth transducer cable. Extension cables are available if the transducer cable is too short.
- If you are not using a repeater or you do not intend to provide NMEA data to another instrument then insulate the bare wire end of the blue cable.

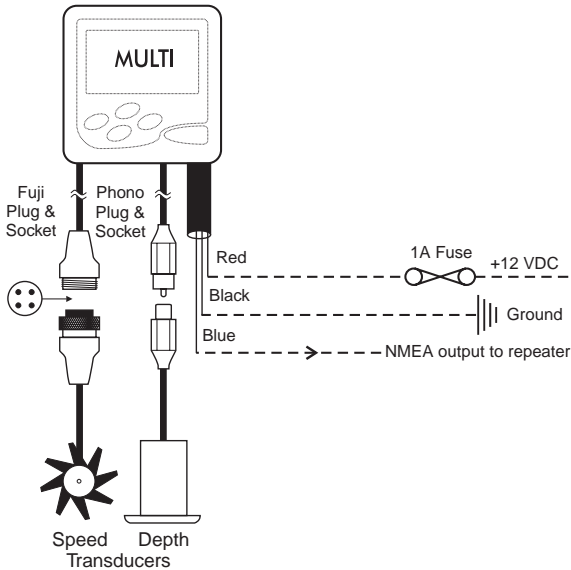

Multiple Instruments

The NAVMAN M100 may be used as an individual instrument or connected with a number of other 100 series instruments to the 100 series repeater or to other instruments accepting NMEA 0183 data.

Operation

Changing Functions

The upper and lower display sections can be configured to display depth or speed readings. The remaining functions are available on either the upper or lower display only.

The \wedge key selects functions available on the upper display. The selection remains in memory after power down.

The \checkmark key selects functions available on the lower display. The selection remains in memory after power down.

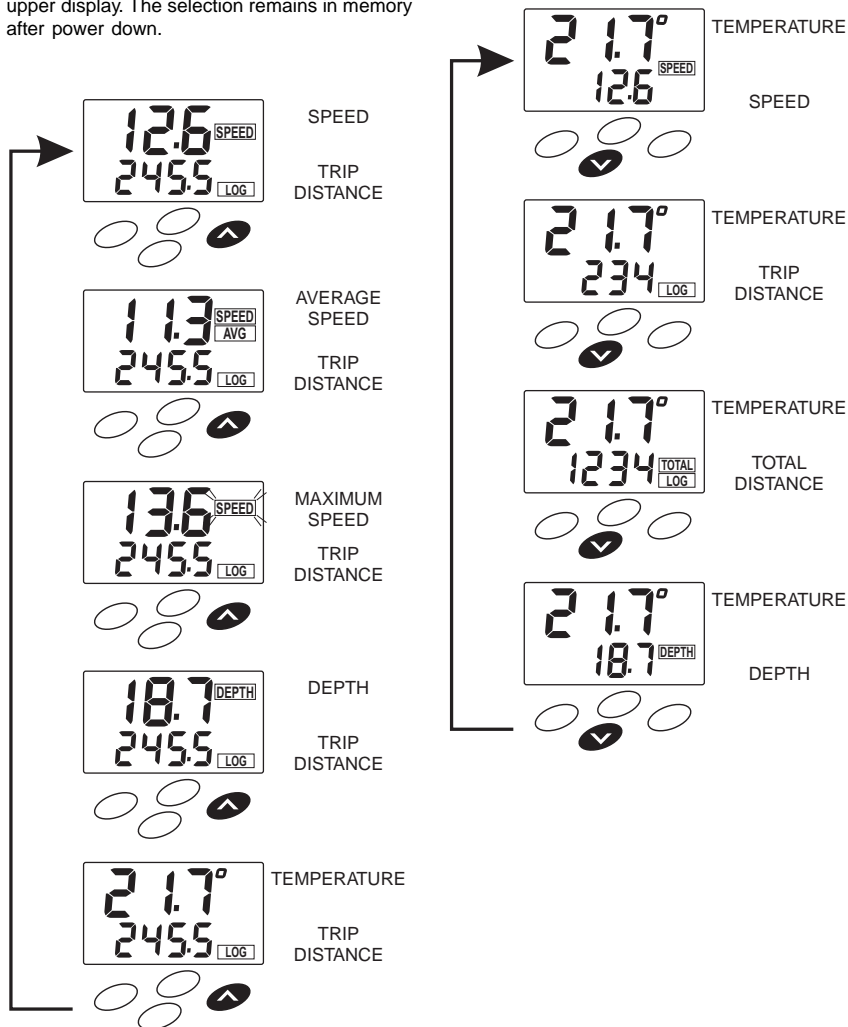

The Depth Alarms

The shallow water alarm sounds when the depth falls below the selected value. The deep water alarm sounds when the depth exceeds the selected value. When an alarm is activated the beeper will sound continuously and the bell alarm symbol will flash.

Setting Alarms

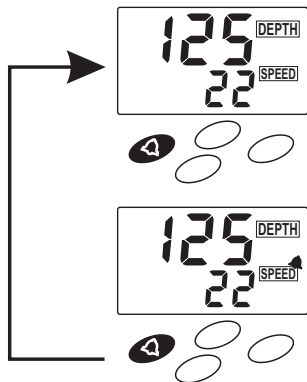

Press the  key to switch the alarm on or off.

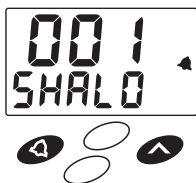

Set Shallow Alarm

Press the  and  keys to enter shallow alarm mode.







Use the  and  keys to set alarm value.
Press the  key to exit.

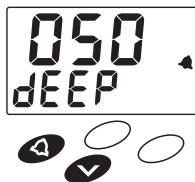

Set Deep Alarm

Press the  and  keys to enter deep alarm mode.



Use the  and  keys to set alarm value.
Press the  key to exit.

Note:

When units are changed, the alarm values are automatically recalculated.

Select Temperature Units

When the top section of the display is indicating temperature, press and hold the  key for three seconds to change the units of measure between °C and °F.

Select Depth Units

When the top section of the display is indicating depth, press and hold the  key for three seconds. The new unit of measure will be displayed for three seconds.

Alternatively, when the bottom section of the display is indicating depth, press and hold the  key for three seconds. The new unit of measure will be displayed for three seconds.

Depth units can be selected in the following order; metres, feet and fathoms.

Timer Functions



All timer functions are displayed on the lower section of the display.

Elapsed Timer

The elapsed timer will record time from power up. Time is displayed in hours and minutes up to 99 hours and 59 minutes.

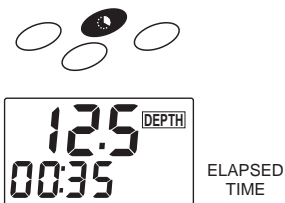
Press the  key to show elapsed time.



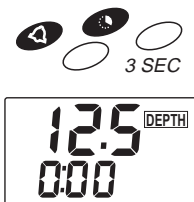

Press and hold the  and  keys for three seconds while the elapsed timer displayed to reset the elapsed time to zero.





Count Down Timer

Press the  key twice to show the count down timer. This timer counts down in seconds from a starting value that can be set in whole minutes from 1 to 10.

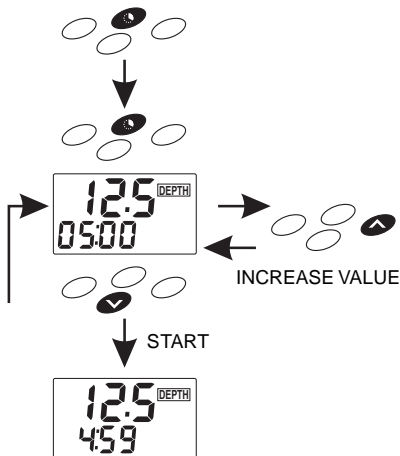
When countdown timer mode is entered the last starting value used is displayed. To start counting down from this value, press the  key. To select a new value to count from, press the  key to scroll through from 1 to 10. When the desired value is displayed press the  key to start it counting down. The count down timer gives audio beeps while counting down, giving 4 beeps at 4 minutes, 3 at 3 minutes, 2 at 2 minutes, 1 at 1 minute, and finishing with 10 beeps. The beep at 0 seconds is a long beep.



To reset the count down timer, press and hold the  and  keys for three seconds while the countdown timer is displayed. The display will return to the start value selection.



Select Speed/Log Units

Speed and distance units can be selected in the following order; Knots (nautical miles), kph (kilometres) and Mph (statute miles).

When the top section of the display is indicating speed, press and hold the \wedge key for three seconds. The new unit of measure will be displayed for three seconds.

Alternatively, when the bottom section of the display is indicating speed, press and hold the \vee key for three seconds. The new unit of measure will be displayed for three seconds.

Note:

When changing speed/distance units, the log and the totals are re-calculated to show the same distance in the new units.

Reset Log (Trip Distance)

With the log displayed, press and hold the \odot and \curvearrowright keys for 3 seconds.

Reset Total Log (Total Distance)

With the total log displayed, press and hold the \odot and \curvearrowright keys for 15 seconds.

Note:

When the total log is reset the trip log and average speed are reset also.

Reset Average Speed

With average speed displayed, press and hold the \odot and \curvearrowright keys for 3 seconds.

Reset Max Speed

With max speed displayed, press and hold the \odot and \curvearrowright keys for 3 seconds.

It is possible to display average speed or max speed and a log value at the same time. In this situation the LAST function to be selected will be reset when the \odot and \curvearrowright keys are held down.

Backlighting On / Off

Simultaneously press the \wedge and \vee keys to turn the backlight on or off.

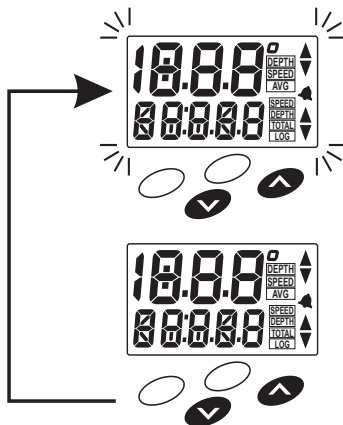

Simulation Mode

The NAVMAN M100 has a simulation mode.

To enter this mode, hold down the \curvearrowright key and then switch on the power. The instrument will remain in this mode even when power is switched off.

Repeat this procedure to exit simulation mode.

Note:

Settings that are made while in simulation mode will remain in effect after returning to normal mode.

Secondary Functions

The secondary modes provide access to keel offset, transducer setting, calibration of boat speed, calibration of water temperature and speed display options of 1/10th or 1/100th units.

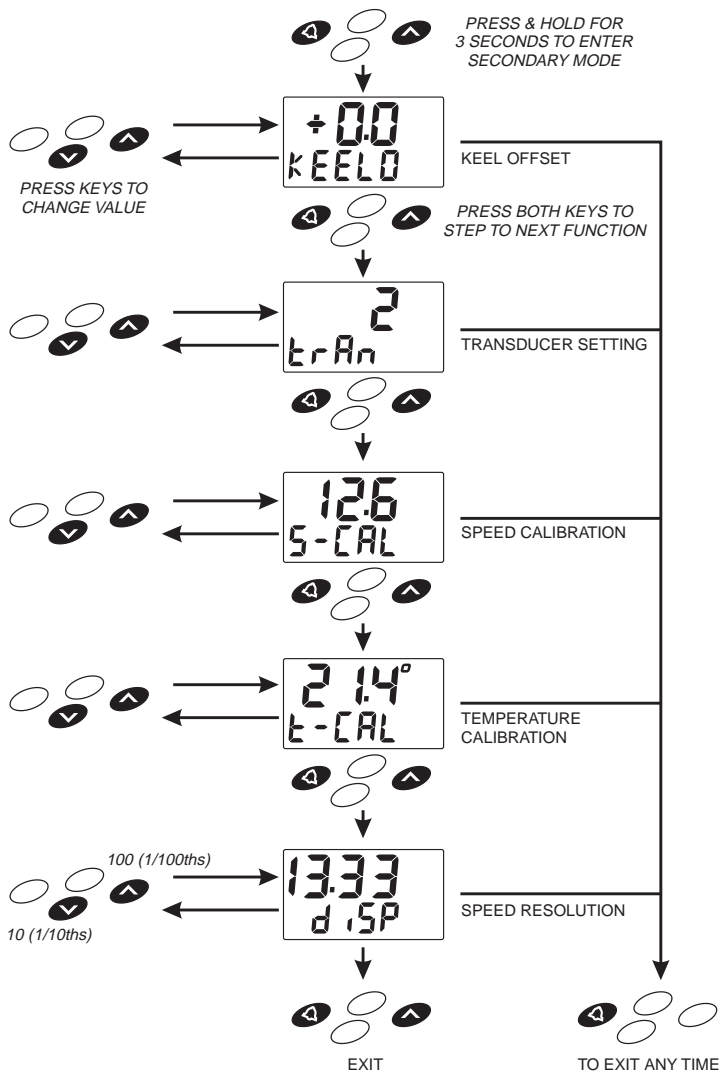

If no key is pressed for 10 seconds, the instrument will exit secondary mode and return the display to normal. Changes made to the secondary function being displayed at this time will not be saved.

Calibration Procedures

Note:

If the speed and depth readings flash, this indicates that the calibration values have been lost. To correct this, check the depth units, alarm values, keel offset, speed units and the speed calibration.

Keel Offset

The NAVMAN M100 will normally display the depth of water below the face of the transducer. You may introduce a negative keel offset equal to the distance from the transducer to the bottom of the keel to display the depth of the water below the keel. A positive offset equal to the distance from the waterline to the transducer can be used to display the total depth from the water surface to the bottom. This is often called a waterline offset.

Follow the Secondary Functions chart to reach Keel Offset mode.

Use the \wedge or \vee key to set the required value.

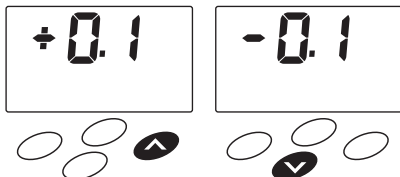

When the required value is displayed press the \hookrightarrow key. The value will be stored in memory.

Note:

When the depth units are changed the keel offset value will automatically be recalculated and displayed in the new units.

Transducer Setting

Three values of transducer setting can be selected (1 to 3). A setting of 3 provides the maximum immunity to turbulence, surface clutter and transducer ringing at the expense of shallow water performance under 4 feet. A setting of 1 enables the M100 to work in water as shallow as 1.8 feet at an increased susceptibility to turbulence. At a setting of 2, the M100 will properly display depths down to 2.9 feet. The default setting is 2.

To enter the transducer setting into memory and exit, press the \hookrightarrow key.

Calibrate Temperature Display

To adjust the temperature displayed.

Follow the Secondary Functions chart to reach Temperature Calibration mode.



To increase reading press the \square key.

To decrease reading press the \vee key.

To enter the calibration setting into memory and exit, press the \hookrightarrow key.

Speed Calibration

Speed Comparison Method

Use the following sequence to adjust the speed displayed to match that of another craft or the speed displayed on a GPS receiver.

Follow the Secondary Functions chart to reach Speed Calibration mode.



To increase reading press the \wedge key.

To decrease reading press the \vee key.

To enter the calibration setting into memory and exit press the \square key.

Note:

When the speed calibration is adjusted the trip log and the average speed will be reset.

Log Calibration Method

Set the log to zero and travel a known distance between two points. *If there is any tidal current, you should travel the course in both directions and use twice the known distance. Try to avoid the situation where the current is flowing at right angles to the course, or if this cannot be avoided, make sure that the boat speed is at least ten times the speed of the current.*

You may calculate a correction factor as follows:

$$\text{correction factor} = \frac{\text{Known distance}}{\text{distance from log}}$$

For example, if you have travelled over a known distance of 1 mile but your log reading is 0.80, the correction factor is 1.25. Therefore, your correct boat speed will be the indicated speed multiplied by 1.25.

Enter the simulation mode by holding down the \square key at power up. When speed is selected in the simulator mode the display will indicate a fixed calibration speed. With the factory default calibration this speed will be 10.0 knots.

Follow the Secondary Functions chart to reach Speed Calibration mode.

Use the \wedge to set the displayed speed to the new value. For our example, assuming we started with the factory default calibration, this new speed would be 10.0×1.25 which is 12.5 knots.

To enter the calibration setting into memory and exit press the \square key.

To exit simulation mode, remove the power and then hold the \square key at power up

Troubleshooting Chart

No display:

Check DC power connections and DC polarity with voltmeter. Voltage must be between 10.7 and 16.6 volts.

No speed reading:

1. Remove speed impellor from skin fitting, spin paddlewheel manually and check for reading.
2. Check for fouling on paddle and skin fitting.
3. Check for break in cable.

Low or high speed reading:

1. Check calibration.
2. Inspect for damage to paddlewheel or fouling of fitting or paddle.

Erratic speed reading:

1. Is there clear water flow over paddlewheel ?
2. Is paddlewheel aligned fore and aft correctly ?

No, or inaccurate temperature reading:

1. Check calibration
2. Check for break in cable.

No depth reading (–) at all depths:

1. Check transducer for growth or multiple coats of paint.
2. Check the transducer cable for cuts and sharp bends.
3. Substitute the transducer with a known good transducer hold it over the side of the boat into the water and see if instrument functions. This isolates cause of problem (transducer or instrument).

Erratic depth readings (while moored):

Check transducer for growth or multiple coats of paint.

Erratic depth readings (while underway):

Cavitation (air) under the face of the transducer. Review installation and reinstall if necessary.

When power is applied display digit counts up or down:

See the section on Simulation Mode.

Erratic readings when engine is running:

1. Reroute power and transducer cables away from ignition wires and battery cables.
2. Add feed-through filter capacitor on the positive terminal of the ignition coil.
3. Add alternator whine filter to alternator.
4. Replace spark plug wire with resistive type.

Simulation Mode

If the speed is not changing and reading around 10kts regardless of boat speed then the instrument is in simulation mode.