



[www.plastimo.com](http://www.plastimo.com)  
[sav@plastimo.fr](mailto:sav@plastimo.fr)

# 51136 BATTERY CHARGER 12 Volts – 40 Amps

ENGLISH

## INSTALLATION OF THE BATTERY CHARGER

- Position the charger in a cool, dry and well ventilated space, ensuring a reasonable airflow around the charger. Do not install in a cupboard or sealed compartment.
- Install as close to the batteries as possible, preferably within 2 meters of the batteries.
- This unit is fitted with an automatic 110/230 V crossover as such the following voltage may be used : 80-130 V or 170-280 V at any frequency : 40-400 Hz.
- The further away from the batteries, you have to put the unit, increase the cable thickness to compensate for voltage drops in the line. The cable diameter should be 25 mm<sup>2</sup> for the 12V40A.
- Before switching on the charger, it is important to set up the battery type, Please choose a battery type from below. The highest charge rate (and voltage) will be the open lead acid (set to 14,8 V on high charger) then Gel (set at 14,4 V) then advanced glass matt (set at 14,4 V) (The agm and gel voltage tends to vary with company to company so check which voltage your batteries require).
- If the battery type requires to be reprogrammed, then select the appropriate setting on the dip switch and ensure the charger is switched off then on again for the settings to take effect (This is because the internal software chip requires a re-boot to install the new settings). The settings have not taken effect if the L.E.D. has not changed to the correct colour.
- In the event of different types of batteries, then the lowest battery voltage type must be selected, Never charge a battery on a higher setting that it should.
- Connect the cables as per the diagram, ensure that all the terminals are used. In the event of only one battery being charged, connect the surplus positive output to the other used output. This ensure correct regulation, failure to do this would reduce the charging performance slightly.
- Always connect the cables to the charger first then run them to the batteries, never connect to the batteries and run to the charger.
- Warning : The charger case is earthed as per international regulations. On most boats, the A/C earth is connected to the bonded system and then to the negative of the battery, this means that the case could be negative. If you touch the positive battery cables to the case, then you can set up a dead short to the battery negative via the earth cable and melt the earth cable, this could start a fire. To avoid this, ensure the battery connectors on the output studs do not touch the charger case, use insulated output connectors. It is also recommended that all the charger outputs have a fuse.

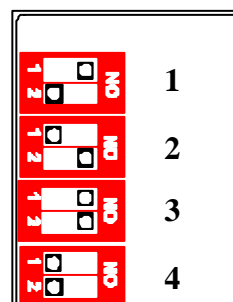
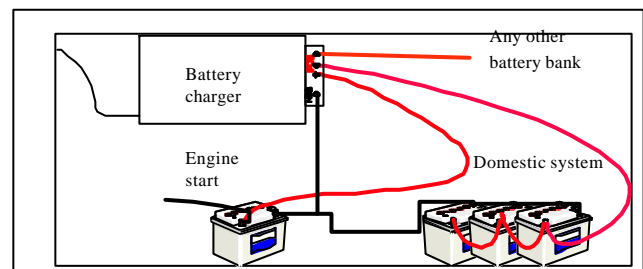
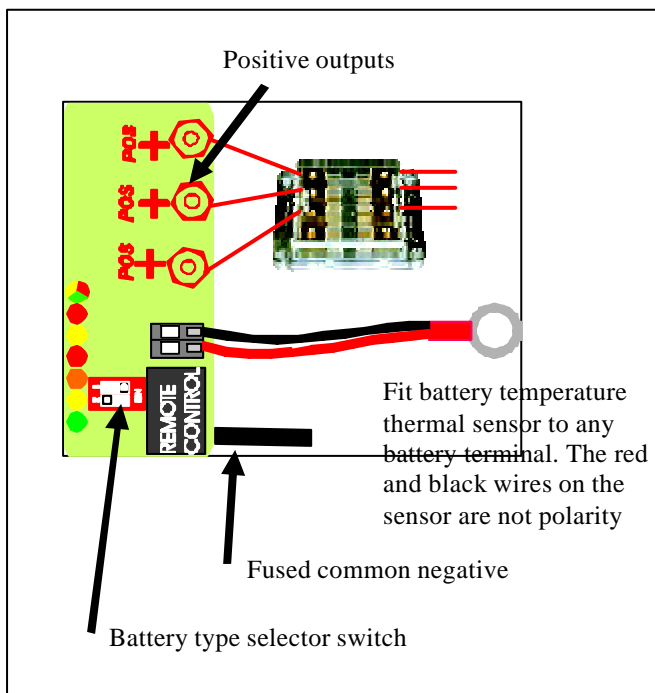

- 1 : Non sealed acid or traction : Yellow led
- 2 : Gel : Green Led
- 3 : Gel USA : Green Led – Flash 10x
- 4 : Sealed acid – Advanced glass matt : Orange Led

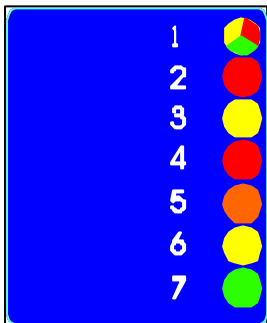

- 1 : Battery type : Ensure that the colour of the Led is in accordance with the battery type selected.
- 2 : Over volt : The red light indicate an over load due to an over chaging (from solar panels for example)
- 3 : High charger temp : The Led becomes yellow and the charger stop when the temperature is too high. Ensure that the fan is working : The charger will restart at a lower temperature.
- 4 : High battery temp : The charger switch off if the battery temperature reach 50 °C. Investigate your batteries, the water level. Restart your charger only if you are sure all is OK
- 5 : Constant current : The Led is orange when there is a constant current from the charger to the batteries.
- 6 : The Led becomes yellow when the voltage reaches 14/28 V. The charger is in step 2 :absorption
- 7 : Float /powerpack : The led indicates that the charger is in step 3 or 4

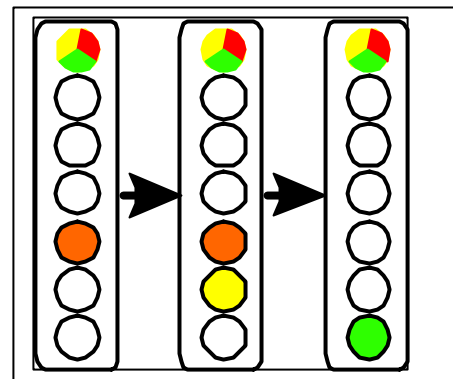
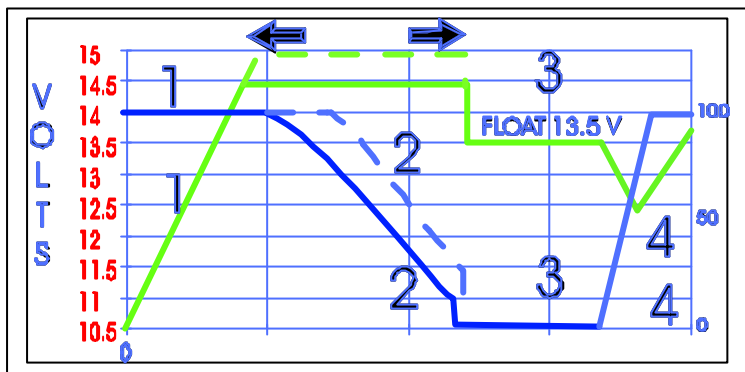

**STEP 1      STEP 2      STEP 3-4**

**4 STEPS CHARGE :**

**STEP 1 – BOOST:** During this period, the charger deliver a maximal current and the tension increase progressively to reach 14,4 V or 14,8 V following the battery type. This step is depending of the initial status of your batteries. The orange led is « on » during this time.

**STEP 2 – ABSORPTION:** Adjustable period where the tension is kept at its maximum and the current decrease regularly in order to optimize the batteries charge. During this time the yellow led is on.

**STEP 3 – FLOAT:** The tension is kept at a level of 13,5 V in order to maintain the charge without increasing the temperature into the batteries. They can be left connected without any damage. The green led is « on ».

**STEP 4 – POWERPACK:** When the batteries tension is 13,5 V, the charger is able to deliver current to the boat appliances without discharging the batteries.

If the batteries voltage goes down below 11,5 V during step 4, the charger restarts at step 1.

<b>Features :</b>	
Input voltage: AC 80-130 V et 170-280 V	Output short protect: Yes
Input frequency: 40-400 HZ	Battery polarity reverse protect: Yes.
Charge: DC 14,4 V or 14,8 V	Over current protect : Yes
Output current: 40 A max	Thermal protect: Yes
Efficiency > 85 %	
<b>DIMENSIONS :</b>	
Length: 300 mm	
Width: 170 mm	
Height: 60 mm	
Weight : 2,5 Kgs	